

Installation Manual

DCT6400 Series
High Definition
Dual-Tuner DVR
Cable Receiver







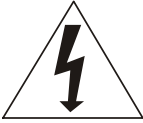

Caution

These servicing instructions are for use by qualified personnel only. To reduce the risk of electrical shock, do not perform any servicing other than that contained in the Installation and Troubleshooting Instructions unless you are qualified to do so. Refer all servicing to qualified service personnel.

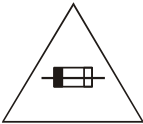
Special Symbols That Might Appear on the Equipment

	This symbol indicates that dangerous voltage levels are present within the equipment. These voltages are not insulated and may be of sufficient strength to cause serious bodily injury when touched. The symbol may also appear on schematics.
	The exclamation point, within an equilateral triangle, is intended to alert the user to the presence of important installation, servicing, and operating instructions in the documents accompanying the equipment.
	For continued protection against fire, replace all fuses only with fuses having the same electrical ratings marked at the location of the fuse.

	This equipment operates over the marked Voltage and Frequency range without requiring manual setting of any selector switches. Different types of line cord sets may be used for connections to the mains supply circuit and should comply with the electrical code requirements of the country of use. The line cord provided with the equipment is acceptable for use with NEMA Style 5-15R ac receptacles supplying nominal 120 Volts.
---	---

WARNING: TO PREVENT FIRE OR SHOCK HAZARD, DO NOT EXPOSE THIS APPLIANCE TO RAIN OR MOISTURE. THE APPARATUS SHALL NOT BE EXPOSED TO DRIPPING OR SPLASHING AND NO OBJECTS FILLED WITH LIQUIDS, SUCH AS VASES, SHALL BE PLACED ON THE APPARATUS.

CAUTION: TO PREVENT ELECTRICAL SHOCK, DO NOT USE THIS (POLARIZED) PLUG WITH AN EXTENSION CORD, RECEPTACLE, OR OTHER OUTLET UNLESS THE BLADES CAN BE FULLY INSERTED TO PREVENT BLADE EXPOSURE.

CAUTION: TO ENSURE REGULATORY AND SAFETY COMPLIANCE, USE ONLY THE PROVIDED POWER CABLES.

It is recommended that the customer install an AC surge arrester in the AC outlet to which this device is connected. This is to avoid damaging the equipment by local lightning strikes and other electrical surges.

FCC Compliance

This equipment has been tested and found to comply with the limits for a Class B digital device, pursuant to Part 15 of the FCC Rules. These limits are designed to provide reasonable protection against harmful interference when the equipment is operated in a residential environment. This equipment generates, uses, and can radiate radio frequency energy and, if not installed and used in accordance with the instructions, may cause harmful interference to radio communications. Operation of this equipment in a residential area is likely to cause harmful interference in which case the user will be required to correct the interference at his/her own expense. Any changes or modifications not expressly approved by Motorola could void the user's authority to operate this equipment under the rules and regulations of the FCC. However, there is no guarantee that interference will not occur in a particular installation. If this equipment does cause harmful interference to radio or television reception, which can be determined by turning the equipment off and on, the user is encouraged to try to correct the interference by one of the following measures:

- Re-orient or relocate the receiving antenna
- Increase the separation between the equipment and receiver
- Connect the equipment into an outlet on a circuit different from that to which the receiver is connected.
- Consult the dealer or an experienced radio/TV technician for help.

You may find the following booklet, prepared by the Federal Communication Commission, helpful: *How to Identify and Resolve Radio-TV Interference Problems*, Stock No. 004-000-0342-4, U.S. Government Printing Office, Washington, DC 20402.

Changes or modification not expressly approved by the party responsible for compliance could void the user's authority to operate the equipment.

Canadian Compliance

This Class B digital device complies with Canadian ICES-003.

Cet appareil numérique de la classe B est conforme à la norme NMB-003 du Canada.

FCC Declaration of Conformity

According to 47 CFR, Parts 2 and 15 for Class B Personal Computers and Peripherals; and/or CPU Boards and Power Supplies used with Class B Personal Computers, Motorola, Inc., 6450 Sequence Drive, San Diego, CA 92121, 1-800-225-9446 or 101 Tournament Drive, Horsham, PA 19044, 1-888-944-4357, declares under sole responsibility that the product identifies with 47 CFR Part 2 and 15 of the FCC Rules as a Class B digital device. Each product marketed is identical to the representative unit tested and founded to be compliant with the standards. Records maintained continue to reflect the equipment being produced can be expected to be within the variation accepted, due to quantity production and testing on a statistical basis as required by 47 CFR 2.909. Operation is subject to the following condition: This device must accept any interference received, including interference that may cause undesired operation. The above named party is responsible for ensuring that the equipment complies with the standards of 47 CFR, Paragraphs 15.107 to 15.109

Repairs: If repair is necessary, call the Motorola Repair Facility at 1-800-227-0450 for a Return for Service Authorization (RSA) number before sending the unit. The RSA number must be prominently displayed on all equipment cartons. Pack the unit securely, enclose a note describing the exact problem, and a copy of the invoice that verifies the warranty status. Ship the unit PRE-PAID to the following address:

Motorola, Inc.
Attn: RSA # _____
5964 E. 14th Street
Brownsville, TX 78521

NOTE TO CATV SYSTEM INSTALLER: This reminder is provided to call CATV system installer's attention to Article 820-40 of the NEC that provides guidelines for proper grounding and, in particular, specifies that the cable ground shall be connected to the grounding system of the building, as close as possible to the point of cable entry as practical.

Copyright © 2004 by Motorola, Inc.

All rights reserved. No part of this publication may be reproduced in any form or by any means or used to make any derivative work (such as translation, transformation or adaptation) without written permission from Motorola, Inc.

Motorola reserves the right to revise this publication and to make changes in content from time to time without obligation on the part of Motorola to provide notification of such revision or change. Motorola provides this guide without warranty of any kind, either implied or expressed, including, but not limited to, the implied warranties of merchantability and fitness for a particular purpose. Motorola may make improvements or changes in the product(s) described in this manual at any time.

MOTOROLA and the Stylized M Logo are registered in the US Patent & Trademark Office. Dolby Digital manufactured under license from Dolby Laboratories Licensing Corporation. Dolby, Dolby Digital, ProLogic and the double-D symbol are registered trademarks of Dolby Laboratories Licensing Corporation. DOCSIS is a registered trademark of Cable Television Laboratories, Inc. Macrovision is a registered trademark of Macrovision Corporation. All other product or service names are the property of their respective owners. © Motorola, Inc. 2004

Contents

Section 1

Introduction

Features	1-2
Tuners	1-2
Standard Audio/Video Features.....	1-2
Standard DVR Functionality.....	1-2
Standard Data Features	1-3
Standard Miscellaneous Features	1-3
Available Optional Features.....	1-3
Using This Manual	1-4
Related Documentation	1-4
Document Conventions.....	1-4
If You Need Help.....	1-5
Calling for Repairs	1-5

Section 2

Overview

Front Panel	2-1
Rear Panel.....	2-2

Section 3

Installation

Important Safety Considerations	3-1
During Transportation to the Subscriber Home.....	3-1
During Installation.....	3-1
Before You Begin	3-2
Clearing the Hard Drive	3-2
Video Connection Options	3-3
Audio Connection Options.....	3-3
Installation Overview	3-4
Cabling to an HDTV for Video.....	3-5
Cabling to an HDTV and Audio/Video Receiver	3-6
Cabling to a Standard Definition TV and Audio/Video Receiver	3-7
Cabling to a Standard Definition TV and Audio Receiver	3-8
Installing the Optional IR Blaster	3-9
Locating the IR Receiver on the VCR.....	3-9
Connecting the IR Blaster	3-10
Checking the IR Blaster	3-10

Data Device Connections3-11

Boot Cycle.....3-12

 Boot Cycle Error Codes3-13

Operational Check for the Remote Control.....3-14

Optimizing the High-Definition Settings.....3-15

 Graphics Overlaying the Video3-17

Section 4

Diagnostics

Using the Diagnostics4-2

d01 General Status4-3

d02 Purchase Status4-4

d03 Out-Of-Band (OOB) Status4-5

d04 In-Band Status4-6

d05 Unit Address4-8

d06 Current Channel Status4-10

d07 RF Modem (Upstream)4-12

d08 Code Modules4-13

d09 Memory Configuration4-15

d10 Keypad - LED4-15

d11 Interface Status.....4-16

d12 User Setting Status4-18

d13 DVR/Hard Drive Status.....4-20

d14 Interactive Info4-22

Section 5

Troubleshooting

Appendix A

Specifications

Appendix B

Connection Record

Abbreviations and Acronyms

Figures

Figure 1-1 DCT6400 front and rear views	1-1
Figure 2-1 Front panel	2-1
Figure 2-2 Rear panel.....	2-2
Figure 3-1 Cabling to an HDTV	3-5
Figure 3-2 Cabling to an HDTV and audio/video receiver	3-6
Figure 3-3 Cabling to a standard-definition stereo TV	3-7
Figure 3-4 Cabling an audio receiver	3-8
Figure 3-5 IR transmitter installed in mounting bracket	3-9
Figure 3-6 IR Blaster installed	3-10
Figure 3-7 Sample data devices you can connect to the DCT6400.....	3-11
Figure 4-1 Example of the LED for the main menu.....	4-2
Figure 4-2 Example GENERAL STATUS LED (no error)	4-3
Figure 4-3 LED display for PURCHASE STATUS diagnostic.....	4-4
Figure 4-4 LED display for the OOB diagnostic.....	4-5
Figure 4-5 LED display for in-band diagnostic	4-6
Figure 4-6 LED display of a unit address	4-8
Figure 4-7 Current channel status LED displays.....	4-10
Figure 4-8 RF upstream modem LED display	4-12
Figure 4-9 LED display for code modules	4-13
Figure 4-10 Interactive Info LED display.....	4-22
Figure B-1 Connection record	B-1

Tables

Table 1-1 DVR Recording Time Guidelines	1-3
Table 2-1 Front panel	2-1
Table 2-2 Rear panel connections	2-3
Table 3-1 LED displays and OOB frequencies	3-12
Table 3-2 Boot cycle error codes	3-13
Table 3-3 Operational check	3-14
Table 3-4 Modes supporting graphics overlay.....	3-17

Section 1 Introduction

The Motorola DCT6400 series advanced digital set-top family targets high-definition (HD) video and dual-tuner digital video recorder (DVR) cable services. It includes a high-end microprocessor, expanded memory, and enhanced graphics to support digital, on-demand, and analog broadcast and interactive services. It provides a full complement of interconnection options.

The DCT6400 family offers advanced capabilities, including:

- Authorization and purchase of on-demand programming
- High-definition television (HDTV) video decoding
- HDTV output through component video (Y Pb Pr), DVI-D, or IEEE 1394 Firewire
- Surround-sound audio through a variety of analog and digital interconnection options
- Dual-tuner DVR functionality to pause and time shift live video and seamlessly record in conjunction with the electronic programming guide (EPG)
- Built-in DOCSIS® cable modem
- Ethernet and Universal Serial Bus (USB) ports for future home networking applications
- Adaptability to various software platforms

As with all Motorola digital set-tops, the hardware features are enabled by core operating and third party application software.

Figure 1-1
DCT6400 front and rear views

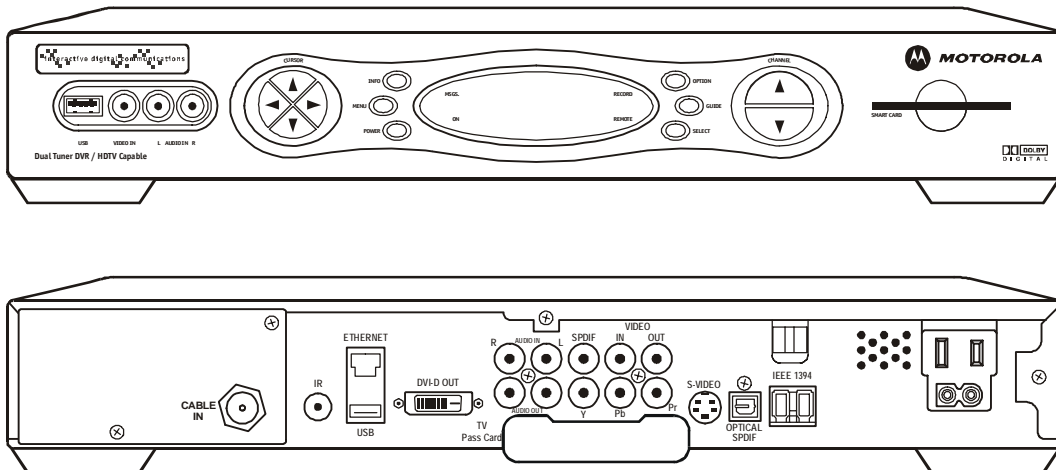

Features

Tuners

Two 54 to 860 MHz video tuners with analog AMS-VSB and digital MPEG-2 main profile high level video processor

One dedicated tuner for the DOCSIS high-speed data/voice services channel, up to 860 MHz

One dedicated tuner for the out-of-band (OOB) control channel

Standard Audio/Video Features

ITU standard 64/256 QAM/FEC/enhanced adaptive equalizer

Clear analog channel processor with BTSC decoder

DES based encryption/DCII access control

Out-of-band data receiver (70-130 MHz) 2.048 Mbps

Audio/video input ports (front and rear)

Analog/digital video scaling (picture in graphics)

32-bit 2D/3D graphics support in hardware

Macrovision® copy protection

High-definition video output through:

- DVI-D
- Component Video (Y Pb Pr)
- Dual IEEE 1394 connectors

Standard-definition video output through:

- S-Video
- Baseband

Audio output through:

- S/PDIF ATSC standard Dolby Digital® AC-3 electrical or optical
- Baseband L/R

Standard DVR Functionality

DVR functionality integrated with the EPG enables subscribers to:

- Pause, rewind, fast-forward, or record live TV
- Maintain a personal recorded program library and access it using the EPG
- Select programs to record across multiple channels and time slots
- Rewind and replay recorded programs
- Simultaneously watch two programs, switching easily between them using the SWAP key
- Record a program in the background while viewing another live program
- Simultaneously record programs from two channels while watching a different pre-recorded program, with the ability to switch viewing between any of the three programs

Motorola cannot guarantee the exact amount of programming that each subscriber will be able to record. The approximate time depends on the programming type and the drive size:

Table 1-1
DVR Recording Time Guidelines

Model	Drive Size	Estimated Recording Hours For		
		Analog Channels	Standard Digital Channels	HDTV Channels
DCT6408	80 MB	20 to 25	50 to 60	8 to 15
DCT6412	120 MB	30 to 37	75 to 90	12 to 20
DCT6416	160 MB	40 to 50	100 to 120	16 to 25

All times are approximate. The DCT6408, DCT6412, and DCT6416 are collectively referred to in this manual as the “DCT6400.”

Standard Data Features

Integrated DOCSIS 1.0/1.1 capable cable modem

16 MB flash memory

128 MB SDRAM

One rear and one front Universal Serial Bus (USB) port (dual connector interface)

10/100 Base-T Ethernet Port (RJ-45)

On-board real-time RF return (DOCSIS compliant)

Renewable security connector

Standard Miscellaneous Features

Smart Card interface for electronic commerce

Infra-Red (IR) blaster port

Switched accessory outlet

Messaging capabilities

Digital diagnostics

Full feature access from front panel using a four-digit, seven-segment LED display

Available Optional Features

Factory-installed expansion flash memory (32 MB)

IR Blaster transmitter

Using This Manual

This manual provides instructions to install and configure a DCT6400:

- | | |
|-----------------------------------|--|
| Section 1 | Introduction provides a product description, a list of related documentation, the technical help line telephone number, and the repair/return procedure. |
| Section 2 | Overview describes the set-top and provides an overview of its use. This section also identifies the front-panel displays and keys and describes the rear-panel features. |
| Section 3 | Installation provides instructions on how to install the set-top in a subscriber location and perform operational tests. |
| Section 4 | Diagnostics provides instructions on accessing and interpreting the built-in diagnostics. |
| Section 5 | Troubleshooting provides information on common error conditions and their resolution. |
| Appendix A | Specifications provides the set-top's technical specifications. |
| Appendix B | Connection Record provides a diagram for recording the connections between the set-top and other devices. |
| Abbreviations and Acronyms | The Abbreviations and Acronyms list contains the full spelling of the short forms used in this manual. |

Related Documentation

The following documentation may be helpful when operating the DCT6400:

- *DCT6400 Series User Guide*
- User documentation for the remote control, audio receiver, TV, and other components

Separate instruction manuals are available for associated components.

Document Conventions

Before you begin working with this manual, familiarize yourself with the following stylistic conventions:

- | | |
|---------------------------|--|
| SMALL CAPS | Denotes silk screening on the equipment, typically representing front- and rear-panel controls, input/output (I/O) connections, and LEDs |
| * (asterisk) | Indicates that several versions of the same model number exist and the information applies to all models; when the information applies to a specific model, the complete model number is given |
| <i>Italic type</i> | Used for emphasis |
| Courier font | Displayed text |

If You Need Help

If you need assistance while working with the DCT6400, contact the Motorola Technical Response Center (TRC):

- Inside the U.S.: **1-888-944-HELP (1-888-944-4357)**
- Outside the U.S.: **215-323-0044**
- Motorola Online: <http://businessonline.motorola.com>

The TRC is open from 8:00 AM to 7:00 PM Eastern Time, Monday through Friday and 10:00 AM to 5:00 PM Eastern Time, Saturday. When the TRC is closed, emergency service *only* is available on a call-back basis. Web Support offers a searchable solutions database, technical documentation, and low priority issue creation/tracking 24 hours per day, 7 days per week.

Calling for Repairs

If repair is necessary, call the Motorola Repair Facility at **1-800-227-0450** for a Return for Service Authorization (RSA) number before sending the unit. The RSA number must be prominently displayed on all equipment cartons. The Repair Facility is open from 8:00 AM to 5:00 PM Central Time, Monday through Friday.

When calling from outside the United States, use the appropriate international access code and then dial **956-541-0600** to contact the Repair Facility.

When shipping equipment for repair, follow these steps:

- 1 Pack the unit securely.
- 2 Enclose a note describing the exact problem. Complete and enclose the checklist provided with the unit.
- 3 Enclose a copy of the invoice that verifies the warranty status.
- 4 Ship the unit **PREPAID** to the following address:

Motorola, Inc.
c/o Rudolph Miles & Son, Inc.
Attn: RSA # _____
5964 E. 14th Street
Brownsville, TX 78521

Section 2 Overview

This section describes the DCT6400 series front and rear panel.

Front Panel

The front panel contains selection and tuning buttons, various displays, the power switch, and connectors for USB, audio and video. The front panel controls provide functional navigation of the DCT6400 if the remote control is lost or is temporarily out of service. Certain functions, such as those requiring a numeric entry, require a remote control.

Some connectors are not enabled and require the support of application software.

Figure 2-1
Front panel

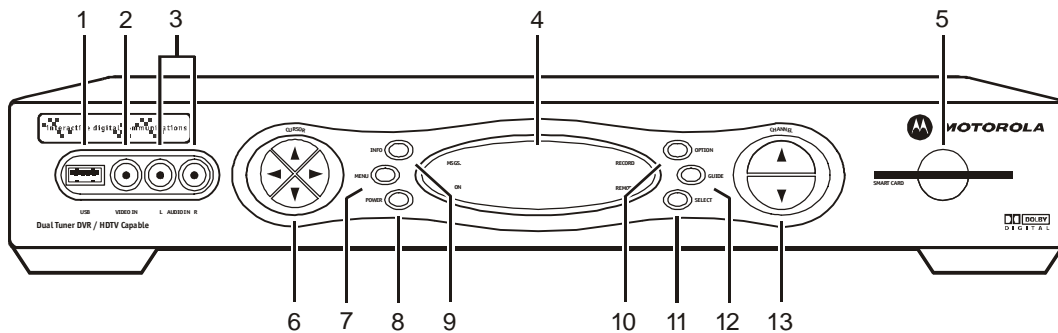



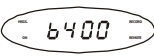











Table 2-1
Front panel

Key	Feature	Function
1*	 USB	The Universal Serial Bus (USB) connector for devices such as keyboards, joysticks, scanners, disk storage, PCs, printers, or digital cameras.
2*	 VIDEO IN	Accepts baseband video from a VCR, camcorder, or other video device.
3*	 L AUDIO IN R	Accepts audio from a VCR, camcorder, or other audio device.
4		The LED displays the channel number or time of day. The indicator lights are: <ul style="list-style-type: none"> ▪ MSGS. — the DCT6400 has received messages for you to read ▪ ON — the DCT6400 is powered on ▪ RECORD — the DVR is recording ▪ REMOTE — the remote control is in use
5*		Supports electronic commerce activity using a Smart Card.

Key	Feature	Function
6		Moves the cursor around the program guide and menu screens.
7		Displays the main menu.
8		Turns the device on or off.
9		Displays the current channel and program information (not supported by all applications).
10		Reserved for future use.
11		Selects menu options or programs from the program guide.
12		Displays the program guide.
13		Changes the channels by moving up or down.

* These connectors are not enabled and require the support of the application software.

Rear Panel

The rear panel contains a switched power outlet; connectors for video, audio, and RF cabling; data output; and modem and data interface connectors.

Some connectors are not enabled and require the support of application software.

Figure 2-2
Rear panel

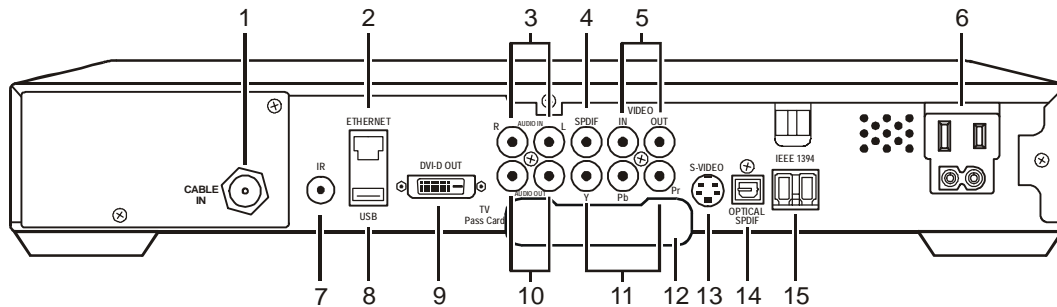









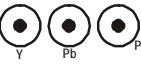





Table 2-2
Rear panel connections

Key	Item	Function
1		F-type connector used for the coaxial cable input from service provider (input to integrated RF return).
2*		Ethernet 10Base-T port supports PC networking.
3*		RCA jacks for loop-through audio from audio equipment.
4		Digital output that carries Dolby Digital 5.1 audio or PCM audio.
5		VIDEO IN – RCA jack connects the DCT6400 to a composite (baseband) video input from a TV, VCR, camcorder, or other video device. <i>Not enabled at this time.</i> VIDEO OUT – RCA jack to deliver video to a device such as a VCR or TV. Enabled.
6		AC power outlet that can be configured as a switched or unswitched outlet; and a two-pronged plug for attaching a power cord.
7		Mini phono jack enabling the DCT6400 to control a VCR using an optional low power IR Blaster transmitter (not all electronic program guides support this feature).
8*		USB connector for devices such as keyboards, joysticks, scanners, disk storage, PCs, printers, or digital cameras.
9		Digital Video Interface (DVI) connector to an HDTV.
10		Left and right audio RCA jacks for stereo audio output.
11		RCA connectors to an HDTV.
12		TV passcard interface.
13		Coaxial cable connector used to deliver high quality video to external devices that accept S-Video inputs, such as a high-end VCR or TV.
14		Optical digital output that carries Dolby Digital 5.1 audio or PCM audio.
15		IEEE 1394 connector for connecting to audio and video devices such as a DTV.

* These connectors are not enabled and require the support of the application software.

Section 3

Installation

This section provides instructions to cable the DCT6400 and check its operation. The cabling diagrams illustrate connections to:

- High- or standard-definition TVs
- Home theater receivers and stereo VCRs

Important Safety Considerations

An advanced set-top containing an internal hard drive requires careful handling to avoid damaging the drive. Be sure to follow these guidelines.

During Transportation to the Subscriber Home

Transport the set-top in its shipping box or an equally padded container.

Transport the set-top in a vehicle from 41°F (5°C) to 122°F (50°C).

Do not expose the set-top to rain or moisture.

Do not drop the set-top or expose the set-top to shock or vibration.

To avoid damage from condensation, avoid drastic temperature changes.

During Installation

To maintain normal operating temperature, provide for adequate ventilation and airflow around the set-top. If you must transport or store the set-top in a cold or hot vehicle, allow time for the set-top to adapt to the temperature in the subscriber home before applying AC power.

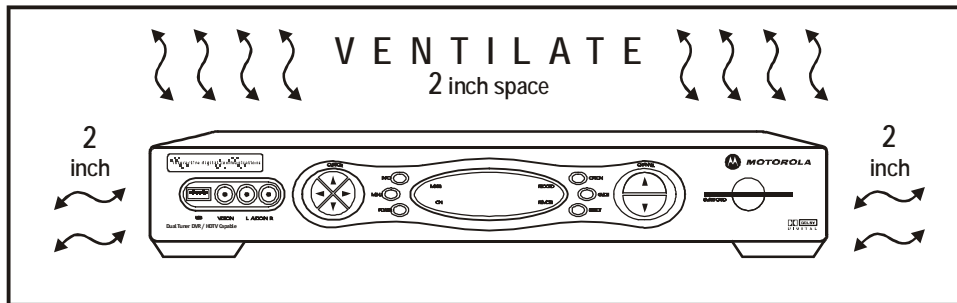

Position the set-top on a flat surface with at least 2 inches of air space above and on all sides to allow free airflow around the unit.

Do not block the slots, openings, and air vents on the set-top.

Do not place anything on top of the set-top.

Do not position the set-top in an enclosed entertainment center or cabinet that does not provide adequate ventilation.

Do not position the set-top near any external heat source that could raise the temperature around the unit. Do not place the set-top on top of another heat-producing electronic device.

Do not plug the AC power cord into a switched power outlet.

Before applying AC power, ground the set-top by connecting it to the coaxial cable wall outlet.

Do not apply power until the set-top has acclimated to the operating environment. It should acclimate 54°F (30°C) per hour to a temperate change. For example, consider moving a set-top that has been in a 41°F (5°C) truck for more than one hour into a subscriber home with a temperature of 77°F (25°C). In this case, you should allow the set-top to warm up for at least 40 minutes before applying power.

Do not apply power to set-top until it reaches a safe operating temperature of 59 to 104°F (15 to 40°C) and 5 to 90% non-condensing humidity.

To allow the internal disk drive to spin down and park its heads, wait 10 seconds after disconnecting power before moving the set-top.

Before You Begin

Before you move or change components on the subscriber entertainment system:

- Review the installation instructions.
- Determine if you are connecting the set-top to a standard TV, a composite (baseband) monitor, or a component monitor.
- Verify that you have the necessary audio/visual cables and other required items.
- If the set-top was previously used, clear its hard drive before installing the set-top at a new subscriber location

Clearing the Hard Drive

On a previously-used set-top, delete all recorded programs from the hard drive before installing it at a new subscriber location. This prevents your new subscriber from viewing programming they may not have purchased or may not want to see.

To prevent subscribers from accidentally deleting all of their recorded programs, a specific set of keystrokes is required to clear the hard drive. Having a TV connected to the set-top is optional.

To clear the hard drive:

- 1** Start the Diagnostics as described in Section 4, “Diagnostics.” d 01 is displayed on the front-panel LED.
- 2** Using a remote control, within five seconds, press REPLAY, MY DVR three times, and LIVE TV. (On some remote controls, the MY DVR key may be labeled “LIST.”)

If you correctly enter this key sequence in five seconds or less, the hard drive is cleared and the front-panel LED displays C1r.

- 3** If C1r is not displayed, re-enter the key sequence in step 2

If C1r is displayed, press any other key to reset the set-top, turn it off, and complete the clearing process.

Video Connection Options

Use the following guidelines to determine the best video connection for the subscriber home entertainment system.

To determine the available video inputs on the TV, check the manual supplied with the TV.

The DCT6400 offers the following video outputs:

Component video (Y Pb Pr)	HDTV and SDTV	The Y Pb Pr outputs provide component video, the most widely supported HD video connection.
S-Video	SDTV <i>only</i>	If the TV has no component video inputs, use the S-Video connection.
Video (composite)	SDTV <i>only</i>	If the TV has no S-Video inputs, use the composite video (VIDEO) connection.
RF	SDTV <i>only</i>	If the TV only has an RF input, connect the DCT6400 using an RF Modulator, which can be purchased at most electronics stores.
DVI-D or IEEE 1394	HDTV and SDTV	DVI and IEEE 1394 offer higher quality HD video than component video. If the TV has a DVI input, use the DVI-D output on the set-top instead of the IEEE 1394 connection. The IEEE 1394 is a video <i>and</i> audio connection, so no audio connections are required if you use the IEEE 1394 connection and plan to use the TV's speakers as the primary audio source.

Audio Connection Options

Connect the stereo audio cable to the **AUDIO R** and **L** connectors on the DCT6400 and the audio left and right connectors on the TV. If the equipment supports it, use the **OPTICAL SPDIF** or coaxial digital **SPDIF** output instead of the AUDIO R and L outputs. In most cases, these outputs offer better audio quality, including support for 5.1 Surround Sound.

When connecting to a home theater receiver, depending on the capabilities of the receiver, you can use the following audio outputs on the set-top:

OPTICAL SPDIF or coaxial SPDIF	If the receiver supports it, use the OPTICAL SPDIF or coaxial SPDIF audio output to deliver Dolby AC-3 audio to a Dolby Digital home theater receiver.
Baseband AUDIO R and L	If the audio receiver does not support Dolby Digital, use the baseband AUDIO R and L outputs to connect to the audio receiver.

The cabling diagrams show sample audio/video connections to an audio receiver, where the receiver functions as an audio/video router. When connecting to an audio receiver, reference its installation instructions for directions on connecting to baseband and S/PDIF ports.

The VCR and TV receive their audio/video signals from the currently selected input device on the audio receiver. This is important when the subscriber has another audio/video device such as a DVD player, a secondary VCR, a CD player, or other electronic component. We recommend connecting the TV to the monitor output so on-screen menus for the receiver can be displayed. (In many cases the receivers themselves have interactive on-screen menus).

Installation Overview

- 1 Determine if you are connecting the set-top to a:
 - High-definition TV or monitor** Use the component video (Y Pb Pr), DVI-D, or IEEE 1394 outputs. *No other video connection supports HDTV.*
 - Standard definition TV** Connect the S-VIDEO connector using an S-video cable or connect the composite VIDEO connector using an RCA phono cable. If the TV only has an RF input, use an RF Modulator, which can be purchased at most electronics stores.
- 2 Determine if you are connecting the audio to a home theater receiver or directly to the TV:
 - For an IEEE 1394 connection, no audio connections are required to the TV.
 - If the receiver or TV has a S/PDIF input, use the OPTICAL SPDIF or coaxial SPDIF outputs.
 - Otherwise, use the baseband left and right AUDIO OUT outputs.
- 3 Locate the cabling diagram(s) that best match the subscriber configuration.
- 4 Connect the audio and video cables in a manner matching that diagram.
- 5 Determine if you are connecting the set-top to a data device (see “Data Device Connections” in this section). For installation details, refer to instructions included with the data device.
- 6 Connect the set-top to the coaxial cable wall outlet.
- 7 Perform the boot cycle, including the download to the set-top, as described in “Boot Cycle” in this section.
- 8 Perform the operational check for the remote control.
- 9 Optimize the high-definition settings. See “Optimizing the High-Definition Settings” in this section.
- 10 Verify that the appropriate configuration information has been downloaded using the addressable controller, such as the DAC 6000.

Cabling to an HDTV for Video

For HDTV video, for the best possible video quality:

- If the TV has a DVI input, connect to the DVI-D connector on the set-top.
- If the TV has no DVI input but does have an IEEE 1394 connector, connect to the IEEE 1394 connector on the set-top. Because IEEE 1394 is a video and audio connection, no audio connections to the TV are required if you use this method.
- Otherwise, use the component video (Y, Pb, and Pr) connectors.

Figure 3-1
Cabling to an HDTV

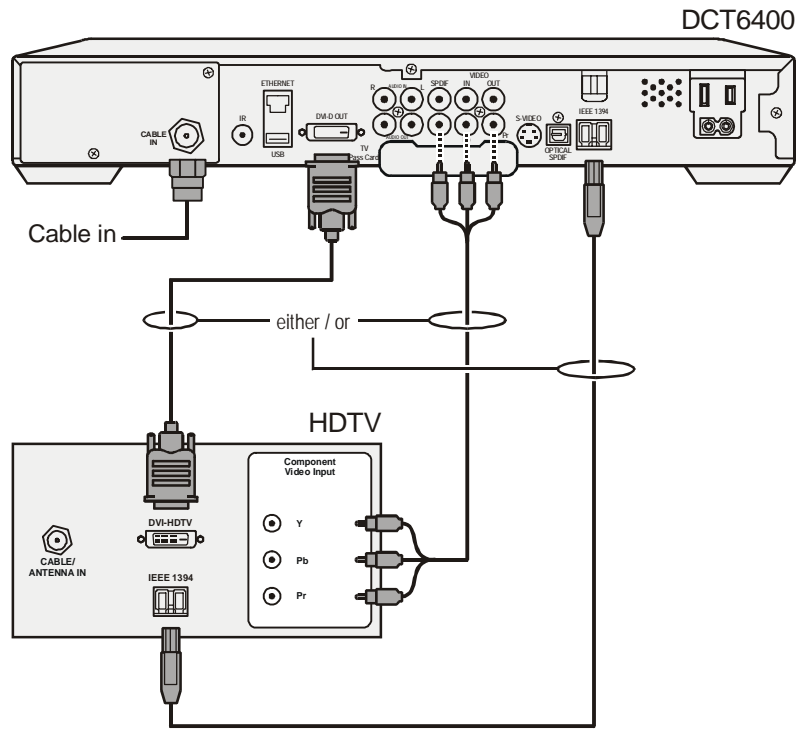

Cabling to an HDTV and Audio/Video Receiver

Figure 3-2
Cabling to an HDTV and audio/video receiver

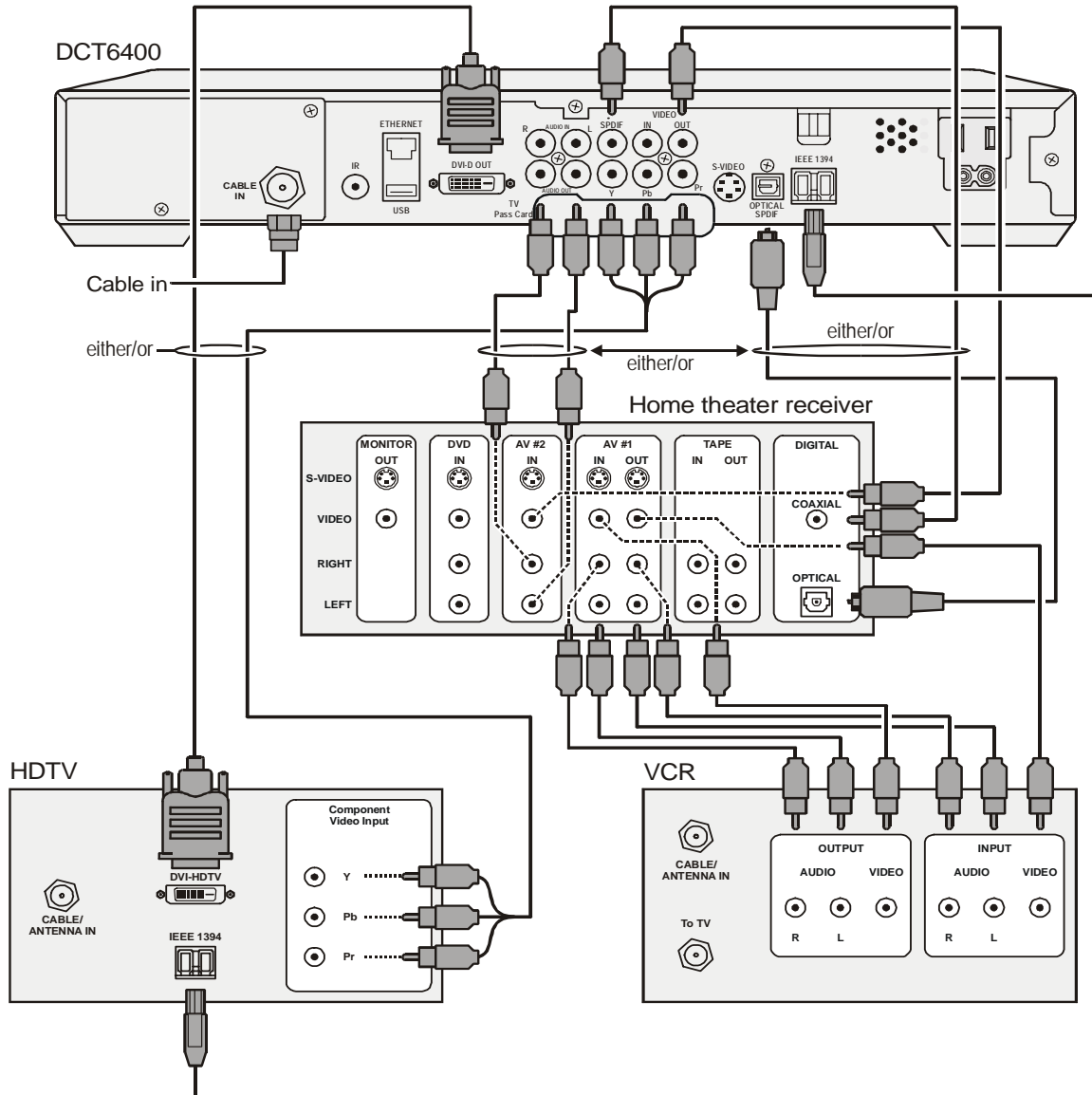

If the receiver can check the baseband and SPDIF ports for appropriate channels, connect both the baseband and SPDIF connections. Otherwise, do not connect both the baseband left/right RCA connections and the RCA SPDIF digital connection. The baseband connections are not necessary because the SPDIF port carries audio for both digital and analog channels providing for a single audio interface.

Cabling to a Standard Definition TV and Audio/Video Receiver

Figure 3-3
Cabling to a standard-definition stereo TV

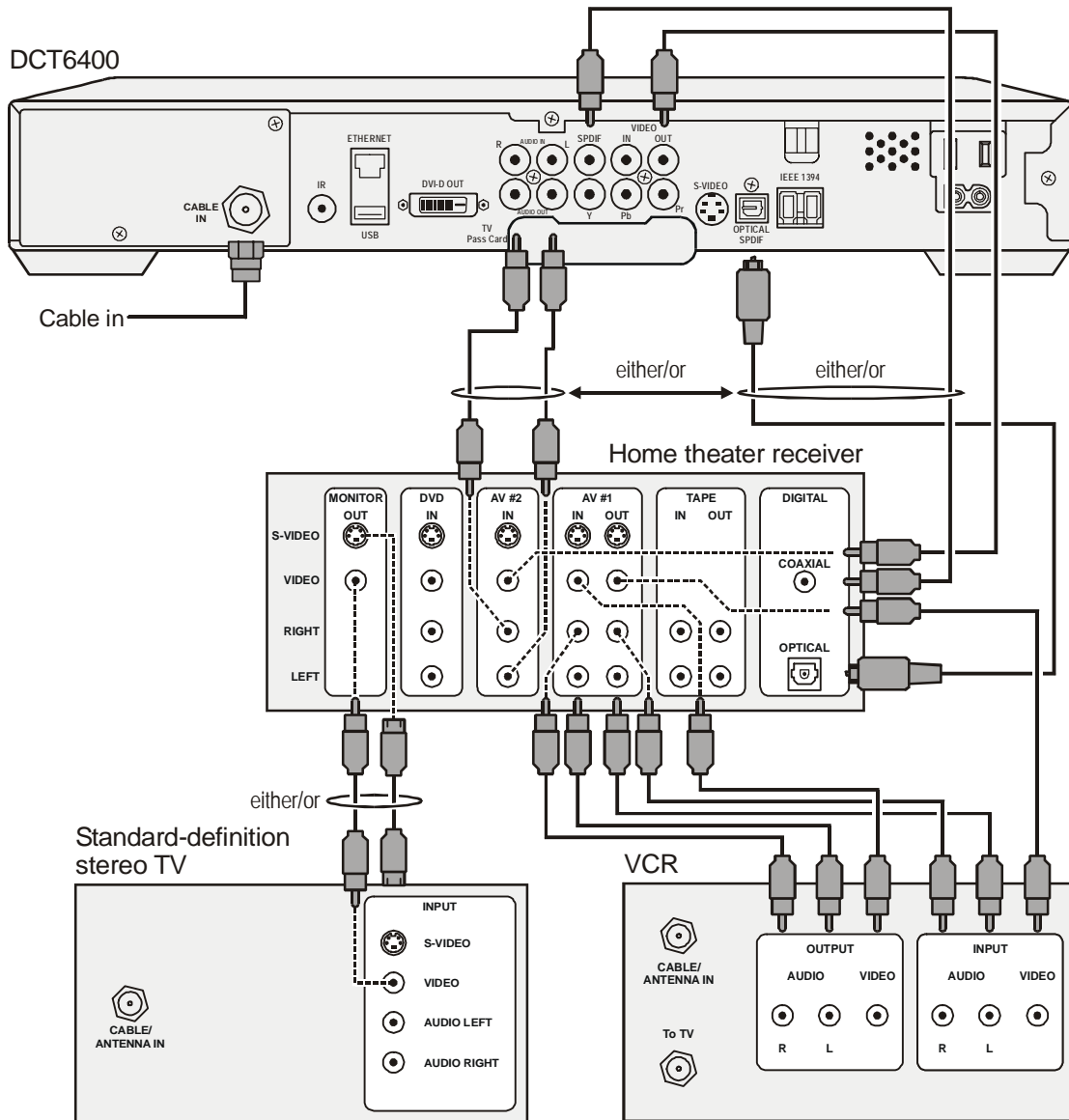

Because some entertainment equipment cannot simultaneously support baseband composite video and S-Video, never simultaneously connect both video inputs.

This connection method does not support HDTV. For information, see “Cabling to an HDTV for Video.”

Cabling to a Standard Definition TV and Audio Receiver

To connect to an audio receiver, such as a home mini system, follow a daisy-chain convention. The audio/video configuration illustrated enables digital stereo recording, including Dolby Surround sound. Use only one set of RCA input connectors on the stereo:

Figure 3-4
Cabling an audio receiver

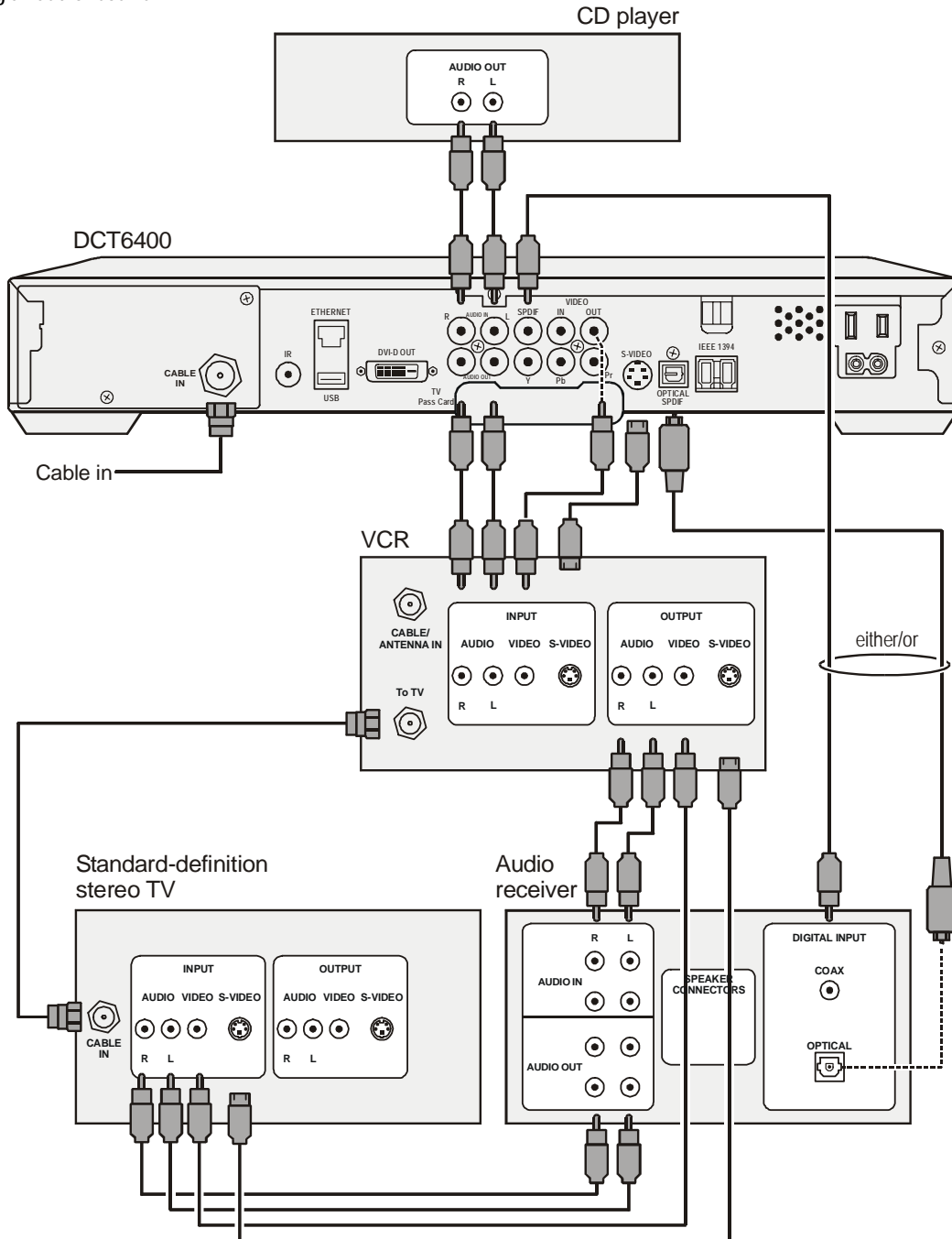

The video connections shown in this illustration do not support HDTV. For information, see "Cabling to an HDTV for Video."

Installing the Optional IR Blaster

The optional IR Blaster provides control of the subscriber VCR from the set-top. It consists of a low-power infrared transmitter attached to a six-foot cord and a mounting bracket. The mounting bracket is a clear plastic holder that has a pad of adhesive tape that enables you to install the IR Blaster near the VCR IR receiver. A mini-pin connector at the end of the cord connects the IR Blaster to the set-top. The IR Blaster is sold separately as an accessory item.

The availability and functionality of the IR Blaster depends on the installed application software. Some EPGs may not support the IR Blaster.

Figure 3-5
IR transmitter installed in mounting bracket

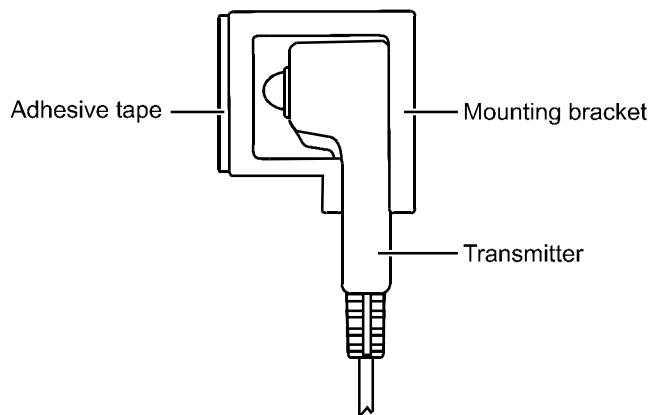

Once installed, the IR Blaster is activated automatically through the electronic program guide. Individual VCR codes are broadcast through the out-of-band data channel and are updated periodically as new codes are added.

The procedure for installing the IR Blaster is described in the following paragraphs.

Locating the IR Receiver on the VCR

The IR receiver area is not visible on some VCRs. To locate it:

- Obtain a piece of opaque material, such as a 3- by 5-inch index card.
- Use the card to block off areas of the VCR where the IR receiver might be located. Try to turn the VCR on and off with the remote control pointed directly at it, and close enough to reduce the possibility that the receiver will see IR reflections.
- Note the blocked area where the VCR is unresponsive to the remote control. This region contains the sensor and can be marked by loosely taping the index card to the area.

Because the IR Blaster radiates in an area approximately 40 degrees wide, you do not need to be precisely on target with the receiver. You may prefer to offset the location of the IR Blaster transmitter so that it is less likely to interfere with operation of the VCR remote control.

Connecting the IR Blaster

To connect the IR Blaster:

- 1 Fit the transmitter into the mounting bracket (refer to Figure 3-5).
- 2 Plug the mini-pin connector into the IR jack on the rear panel of the set-top rear panel as illustrated in Figure 3-6:

Figure 3-6
IR Blaster installed

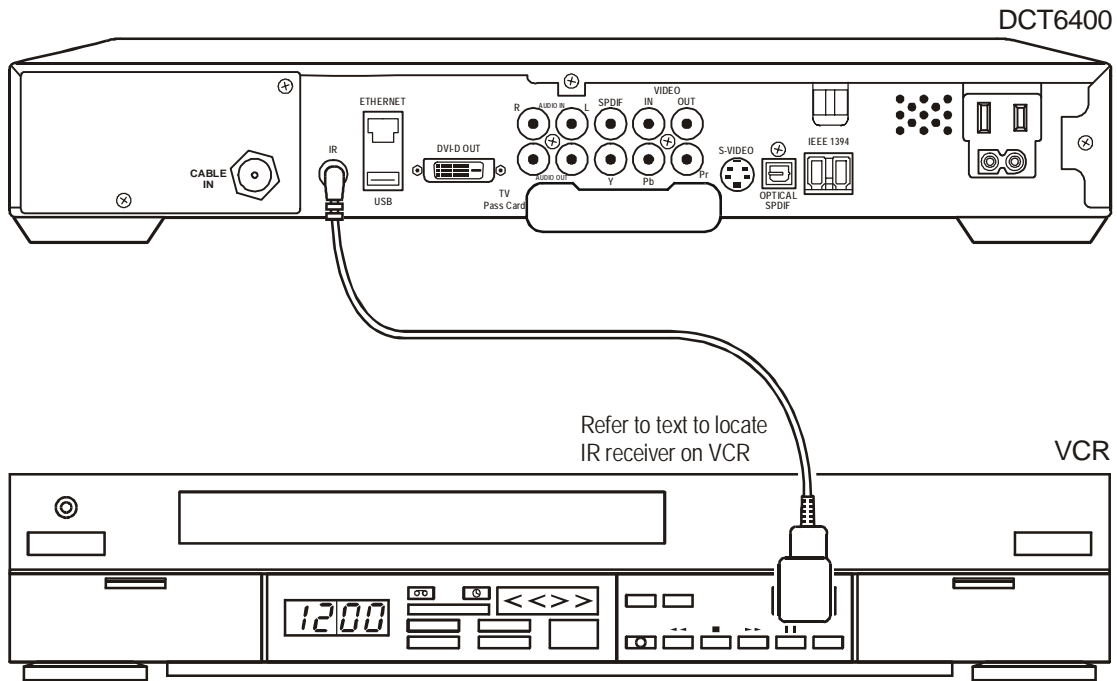

- 3 Remove the adhesive tape cover from the mounting bracket.
- 4 Position and press firmly to attach the mounting bracket to the IR receiver on the VCR. Be careful to route the wire so that it does not prevent loading tapes.

Checking the IR Blaster

The IR Blaster is now located near the receiver and the VCR can be controlled through the set-top. As a final check, operate the VCR using the remote control from various positions in the room. If the IR Blaster is obstructing the IR receiver on the VCR, move it slightly.

Data Device Connections

The DCT6400 provides optional high-speed data services such as Internet access, USB, Ethernet, and more. *The functionality of each data device port requires, and depends on, installed application software.*

The DCT6400 rear panel provides:

Two USB ports Can be used to daisy-chain USB devices such as printers and storage devices, or to interface with USB keyboards, joysticks, and other USB peripherals used for PCs. An additional USB port is available on the front panel.

Ethernet 10Base-T This RJ-45 port can be used to connect the set-top to a home network.

The DCT6400 front panel provides:

USB port Can be used in the same manner as the USB ports on the rear panel.

ISO 7816 Smart Card interface Can be used for electronic commerce.

Figure 3-7
Sample data devices you can connect to the DCT6400

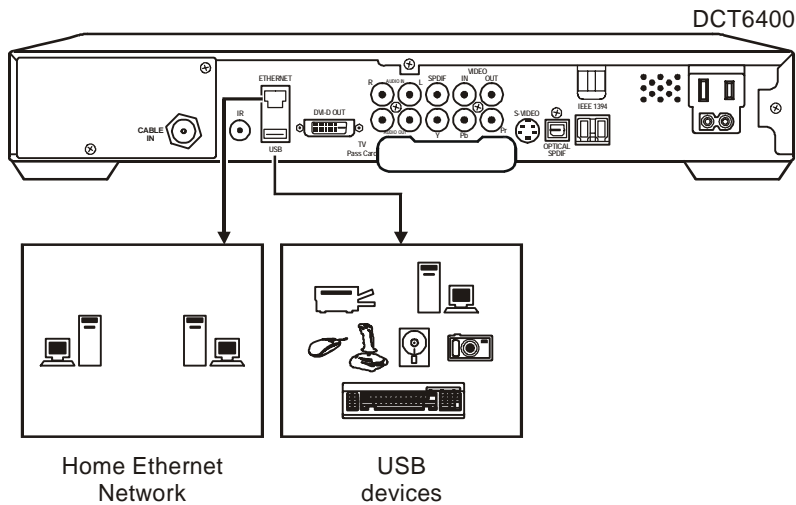

Boot Cycle

After connecting the proper cabling to the set-top, plug the power cord into the set-top and electrical wall outlet. Begin performing the boot cycle procedure:

- After a few moments, the LED displays **HUNT** and then **FR 1**.
- The set-top searches for the headend out-of-band (OOB) frequency carrier. If the OOB frequency is not set to 75.25 MHz, the LED flashes **FR 1** and then flashes **FR 2**. This searching process repeats until the correct OOB frequency is found and the required message for the set-top model is acquired.

The LED displays and OOB frequencies are:

Table 3-1
LED displays and OOB frequencies

Display	Frequency	Description
dl	N/A	OOB network download in progress
EF	N/A	Erasing Flash memory
FP	N/A	Flash memory is being programmed
—	N/A	Network download complete
Hunt	N/A	Hunting for OOB frequency
FR 1	75.25 MHz	Attempting to lock on frequency 1
FR 2	104.20 MHz	Attempting to lock on frequency 2
FR 3	72.75 MHz	Attempting to lock on frequency 3
FR 4	92.25 MHz	Attempting to lock on frequency 4
FR 5	98.25 MHz	Attempting to lock on frequency 5
FR 6	103.75 MHz	Attempting to lock on frequency 6
FR 7	107.25 MHz	Attempting to lock on frequency 7
FR 8	107.40 MHz	Attempting to lock on frequency 8
FR 9	110.25 MHz	Attempting to lock on frequency 9
FR 10	116.25 MHz	Attempting to lock on frequency 10
Au	N/A	Authenticating code object (displays only after download)

- When the correct OOB frequency is acquired, the LED flashes **FR number**.
- When multiple OOB frequencies are used, the set-top pauses 40 seconds on each valid frequency. The LED displays **dl** and a progress indicator, which identifies a software object download. The progress indicator, or crawling ant, moves one position around the **dl** display for each segment of download received. If the **dl** stops moving up and down on the LED for an extended period of time, contact the headend operator.

The progress indicator usually moves at a consistent rate as segment downloads are received. If all the segments are retrieved in the first pass, the **EF**, **AU** and **FP** messages are displayed on the LED. If segments are dropped, the progress indicator appears to stall and then inch forward after the dropped segments are retired.

The software download may take up to 45 minutes (or longer if the system is experiencing high demand). As long as the progress indicator is spinning, the download is progressing.

When the progress indicator alternates between rapid and sluggish movement, this may indicate that the stream is spinning too fast for existing plant conditions.

- When the software object download is complete, the LED displays:
 - EF** For up to 60 seconds during flash erasure
 - FP** For up to 60 seconds during flash programming
- When the LED display is blank, the set-top is ready for initialization and service authorization using the addressable controller. Verify that the set-top is powered up or reset within two minutes of a completed download.

Boot Cycle Error Codes

If hardware or software problems occur, the set-top displays error codes on the LED display. Table 3-2 lists error codes that can occur during boot cycle startup:

Table 3-2
Boot cycle error codes

Code	Description	When Error Occurs	Action Required
Eb 01	Object failed validation	After the LED displays $\alpha 1$, indicating validation check failed	Contact headend operator
Eb 02	Download time-out	After cycling twice through the OOB frequencies	None
Eb 03	Flash erase failed	After software object download complete and EF is displayed	Replace the set-top
Eb 04	Flash programming failed	After software object download complete and FP is displayed	Contact headend operator
Eb 05	Invalid DLC frequency	After the LED displays $\alpha 1$, indicating validation check failed	Contact headend operator
Eb 06	Hardware initialization failed	After plugging the set-top into an electrical outlet to begin the boot cycle	Replace the set-top
Eb 07	Object failed validation	After software object download complete and FP is displayed	Contact the headend operator
		After a successful software object download and the set-top is reset	No action required because the set-top repeats the software object download
Eb 08	Reserved		None
Eb 09	Check failed	Reset within two minutes of a complete software object download	No action required because the set-top repeats software object download process
Eb 10	SUDB recreation	After plugging the set-top into an electrical outlet to begin the boot cycle	None

Code	Description	When Error Occurs	Action Required
Eb 11	Failed to lock OOB frequency	After cycling twice through the OOB frequencies (LED then displays Eb 02 indicating the software object download was unsuccessful)	Ensure proper cable connections
Eb 12	No COAC message received	After cycling twice through the OOB frequencies (LED then displays Eb 02 indicating the software object download was unsuccessful)	Contact headend operator
Eb 13	No DLC message received	After cycling twice through the OOB frequencies (LED then displays Eb 02 indicating the software object download was unsuccessful)	Contact headend operator
Eb 14	Bad object type or class	After the LED displays d1 , indicating failed during attempted download	Contact headend operator
Eb15	No matching Platform ID found	After cycling twice through the OOB frequencies (LED then displays Eb 02 indicating the software object download was unsuccessful)	Contact headend operator
Eb18	Object size mismatch	After the LED displays d1 , indicating failed during attempted download	Contact headend operator
Eb19	Object size failed range check	After the LED displays d1 , indicating failed during attempted download	Contact headend operator
Eb20	Invalid SUDB pointer	After plugging the set-top into an electrical outlet to begin the boot cycle	None

Operational Check for the Remote Control

The operational check tests the communication link between the remote control and the set-top. Table 3-3 lists the operational check procedures:

Table 3-3
Operational check

Feature	Testing Procedure
Power on	Press POWER to turn on the set-top. Tune to the output channel of the set-top (channel 3 or 4).
Channel selection	Scan through the channels using the CHANNEL + or - keys. Tune to several channels by entering the channel number using the numeric keys.
Volume control	Press VOLUME + or - on the remote control to increase the volume to its upper limit, lowest level, and to a comfortable level. Press MUTE to turn the sound off. Press MUTE again to restore the sound.

If the set-top does not operate properly, refer to Section 5, “Troubleshooting”.

Optimizing the High-Definition Settings

The DCT6400 delivers high-quality component video for high-definition TVs using the Y Pb Pr (component) and DVI-D video connectors. This subsection describes how to use the on-screen menu to optimize standard- and high-definition video based on subscriber preferences and configure the high-definition settings.

Before you optimize the set-top output settings:

- Connect the set-top to other home entertainment devices
- Plug the set-top into a power outlet
- Perform the boot cycle
- Initialize the set-top and authorize services
- Turn the set-top off
- Turn the TV on

To optimize the set-top output settings using the on-screen display:

- 1 Power off the set-top and then immediately press the **MENU** key on the front panel. If the TV is on, the on-screen menu lists the settings you can configure:

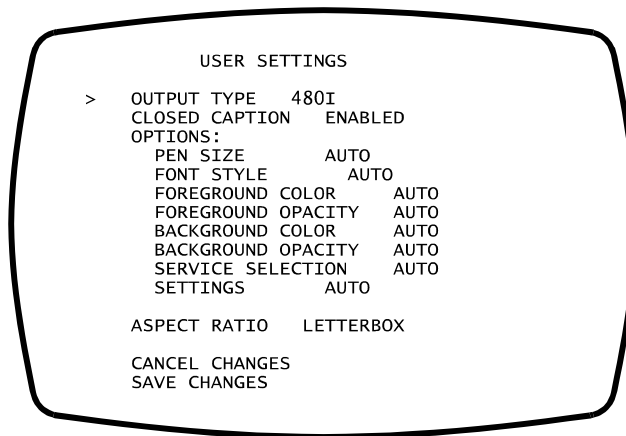

- 2 Use the remote control or the cursor keys on the front panel to navigate the on-screen menus:
 - Press the ▲ and ▼ keys to highlight the setting you wish to change.
 - Press the ► key to select an option.
 - To exit the setting and move to another setting, press the ▲ or ▼ key.

If the on-screen menu does not display on the HDTV screen, the TV may be off or it may not support the default video output setting. Use the set-top front panel LED to adjust the settings as described in “There is no video on the TV screen” in Section 5, “Troubleshooting.”

For a TV with a DVI connection, be sure the TV is on and connected to the set-top DVI-D OUT connector before adjusting the settings.

The high-definition settings are:

Setting	Description
TV Type	<p>Sets the aspect ratio. The LED panel displays the type you select. Defaults to 16:9. Options are 16:9 for wide screen TVs or 4:3 LETTERBOX or 4:3 PAN/SCAN for standard TVs:</p> <ul style="list-style-type: none"> ▪ 4:3 LETTERBOX fits high-definition programming on the screen by placing black bars at the top and bottom. ▪ 4:3 PAN/SCAN fills the screen by cropping the left and right edges of high-definition programming.
DVI/Y Pb Pr Output	<p>Sets the video display format for the component video outputs. The LED panel displays the format you select. Defaults to 1080i. Options are 1080i, 720p, 480p, or 480i.</p> <p>Some TVs only support certain display formats. Check your TV user manual for more information. If you are not using an HDTV, selecting a format other than 480i causes the on-screen display to go blank. If this occurs, you can view the settings on the LED panel to change the format back to 480i.</p> <p>If you are not using the DVI video connection, the DVI/Y Pb Pr OUTPUT setting displays as Y Pb Pr OUTPUT.</p>
4:3 Override	<p>Sets the display format for 4:3 standard-definition programming. If the Y Pb Pr Output is set to 1080i, 720p, or 480p, this setting defaults to 480i. If the Y Pb Pr Output is set to 480i, this setting defaults to OFF and cannot be changed. Options are:</p> <ul style="list-style-type: none"> ▪ OFF displays non-high-definition programs having a 4:3 aspect ratio in wide screen format. On an HDTV, black bars display on the left and right of the picture. Selecting OFF for a 4:3 TV may result in a small picture with black bars around it. ▪ 480i displays non-high-definition programs in their original 480i format. Some TVs cannot display 480i format on their component video inputs (Y Pb Pr). Check the TV user manual for more information. Graphics overlaying the video are displayed. ▪ 480p converts non-high-definition TV programs to a higher-quality 480p format. Some TVs cannot display 480p format on their component video inputs (Y Pb Pr). Check the TV user manual for more information. Graphics overlaying the video are not displayed.
Closed Caption	<p>Turns closed captions off or on. The LED panel displays the status of the closed captions. Defaults to DISABLED. Options are ENABLED or DISABLED.</p>
Pen Size	<p>Sets the font size for closed captions. Defaults to AUTO. Options are AUTO, STANDARD, LARGE, or SMALL.</p>
Font Style	<p>Sets the font style for closed captions. Defaults to AUTO. Options are AUTO, MONO SERIF, PROPORTION SERIF, MONO NO SERIF, PROPORTION NO SERIF, CASUAL, CURSIVE, or SMALL.</p>
Foreground Color	<p>Sets the foreground color for closed captions. Defaults to AUTO. Options are AUTO, WHITE, BLACK, RED, GREEN, BLUE, YELLOW, MAGENTA, or CYAN.</p>
Foreground Opacity	<p>Sets the opacity of the closed captions foreground. Defaults to AUTO. Options are AUTO, TRANSPARENT, TRANSLUCENT, SOLID, or FLASHING.</p>
Background Color	<p>Sets the background color for closed captions. Defaults to AUTO. Options are AUTO, WHITE, BLACK, RED, GREEN, BLUE, YELLOW, MAGENTA, or CYAN.</p>
Background Opacity	<p>Sets the background opacity for closed captions. Defaults to AUTO. Options are AUTO, TRANSPARENT, TRANSLUCENT, SOLID, or FLASHING.</p>
Service Selection	<p>Sets the service for closed captions. Defaults to AUTO. Options are AUTO, PRIMARY LANGUAGE, SECONDARY LANGUAGE, 3, 4, 5, or 6.</p>
Settings	<p>Sets the default settings for closed captions (AUTO) or the settings you have configured (USER). Defaults to AUTO. Options are AUTO or USER.</p>
Restore Defaults	<p>Resets the on-screen display options to their default settings.</p>

- 3** To exit the menu and save your settings, press the **POWER** or **MENU** key.

Graphics Overlaying the Video

The set-top can generate graphics that overlay the video programming or fill the entire television screen. Common examples include on-screen menus (such as the User Setting menu), closed captions, and EPG. The set-top overlays these graphics whenever the subscriber opens a menu, enables closed captions, or scrolls through a program grid.

Overlaying graphics are not available on all DCT6400 video output and mode combinations.

Table 3-1 summarizes the availability of overlaying graphics for each video output combination:

Table 3-4
Modes supporting graphics overlay

DVI or Y Pb Pr Output Mode	DCT6400 Primary Video Output (DVI or Y Pb Pr)	DCT6400 Secondary Video Output		
		S-Video Out	Composite Out	RF Out
1080i	Graphics overlay supported	Video <i>only</i>	Video <i>only</i>	Video <i>only</i>
720p	Graphics overlay supported	Video <i>only</i>	Video <i>only</i>	Video <i>only</i>
480p	Graphics overlay supported	Video <i>only</i>	Video <i>only</i>	Video <i>only</i>
480i	Graphics overlay supported	Graphics overlay supported	Graphics overlay supported	Graphics overlay supported

The 4:3 Override feature enables you to specify a different Output Mode for high-definition (DVI or Y Pb Pr) programming and standard-definition (4:3) programming. If the 4:3 Override is set to 480i and the subscriber tunes to a 4:3 standard channel, the DCT6400 displays graphics overlays on all outputs even if the DVI or Y Pb Pr Output Mode is 1080i, 720p, or 480p.

Section 4

Diagnostics

This section describes the diagnostics that confirm proper set-top installation, including:

- Checking error states and signal integrity
- Identifying the set-top on the network
- Verify communications with the headend

Diagnostics are displayed on the on-screen display (OSD) and front-panel LEDs.

For the diagnostics described in this section:

- All indicators are in decimal notation, unless otherwise noted.
- All signal-level and quality indicators use a 1% to 100% scale, unless otherwise noted.
- All sample displays are illustrative; actual data may differ from the examples.

You can use the diagnostics when running the base platform or Thin Client software.

Using the Diagnostics

To use the diagnostics:

- 1 Ensure that the set-top is installed with the base platform or Thin Client software and that it is connected to an AC outlet.
- 2 Press **POWER** and immediately press **SELECT** to enable diagnostic mode. The Diagnostics main menu is displayed on the OSD and “d01” is displayed on the front-panel LED:

```

                                DIAGNOSTICS
> d01  GENERAL STATUS
    d02  PURCHASE STATUS
    d03  OOB STATUS
    d04  INBAND STATUS
    d05  UNIT ADDRESS
    d06  CURRENT CHANNEL STATUS
    d07  UPSTREAM MODEM
    d08  CODE MODULES
    d09  MEMORY CONFIG
    d10  KEYPAD/LED
    d11  INTERFACE STATUS
    d12  USER SETTING STATUS
    d13  PVR/HDD STATUS
    d14  INTERACTIVE (displayed only when Thin Client is running)
    E    EXIT

```

Figure 4-1
Example of the LED for the main menu



You can use the following keys to navigate the diagnostics menus:

- Press **CHANNEL ▲**, **CHANNEL ▼**, **CURSOR ▲**, or **CURSOR ▼** to select **d01** through **E**.
- Press **CURSOR ◀**, **CURSOR ▶**, **SELECT** or **ENTER** to execute the selected diagnostic.
- Select **E** from the main menu or press **POWER** to exit.

d01 General Status

This diagnostic displays system status information on the OSD and LED. The information is updated each time the diagnostic is displayed.

GENERAL STATUS		
ERROR:	EP00	CONNECTED
PLATFORM ID:	0x025E	
FAMILY ID:	0x0000	
MODEL ID:	0X64CIA	
REMOD CHAN:	03	
SETTOP TIME:	xxxxxxxxx	GPS

Figure 4-2
Example GENERAL STATUS LED (no error)



The General Status fields are:

Field	Description
Error	Error codes display on the LED and OSD when an error occurs. If multiple errors occur, the last recorded error is displayed: <ul style="list-style-type: none"> EP00 No error EP01 Not connected EP03 DRAM error EP04 SRAM error EP07 ROM verification failure EP08 RAM test failure EP09 Battery test failure EP11 Invalid unit address EP12 Power on self test failure EP14 GITV startup failure EP15 TSI structure corrupt EP18 Driver initialization failure
Connected State	A DCT-operations connect or disconnect message determines whether the set-top is in the CONNECTED or DISCONNECTED state.
Platform ID	A unique 16-bit hexadecimal number that identifies the platform image (also called the ROM ID).
Family ID	The set-top manufacturer and product family, in hexadecimal format.
Model ID	The set-top model, in hexadecimal format.
Remod Chan	The interface from the set-top to the subscriber TV; channel 3 or 4 in the USA.
Settop Time	The current OOB set-top time displayed in Global Positioning System (GPS) seconds from Jan 6, 1980. It is an integer from 0 to 4294967295.

d02 Purchase Status

This diagnostic displays the status of subscriber event purchases on the OSD and LED. The OSD and LED information displays are updated each time this diagnostic is displayed:

PURCHASE STATUS	
PURCHASES	
UNSENT:	xx
UNACK:	xx
LAST SEQ NUM:	xxxx
LAST RB TIME:	xxxxxxxxxx
IPPV STATUS:	Enabled

Figure 4-3
LED display for PURCHASE STATUS diagnostic

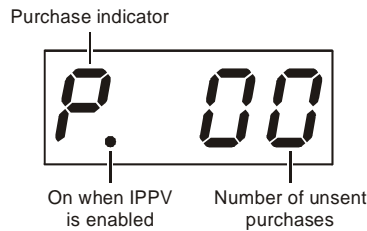

The Purchase Status fields are:

Field	Description
Unsent	The number of purchases in the set-top remaining to be polled. It can be an integer from 0 to 63.
Unack	The number of reports that have not been acknowledged by the controller. It is an integer.
Last Seq Num	The last acknowledged sequence number of a purchase sent by the controller. It is a 16 bit unsigned hexadecimal number.
Last RB Time	The last time the set-top attempted to report back purchases to the controller, in GPS seconds.
IPPV Status	If IPPV is enabled, the IPPV status indicator LED is on. If IPPV is disabled, the IPPV status indicator LED is off.

d03 Out-Of-Band (OOB) Status

This diagnostic indicates the out-of-band control channel status. The information is updated every 5 seconds.

OOB DIAGNOSTIC		
OOB FREQUENCY:	075.25	MHz
CARRIER LOCK:	YES	
DATA:	YES	
EMM DATA:	YES	
SNR:	22.1 dB	GOOD
AGC:	23 %	GOOD
EMM PROVIDER ID:	0x0400	
EMM PID:	0x0403	
NETWORK PID:	0x0003	

Figure 4-4
LED display for the OOB diagnostic

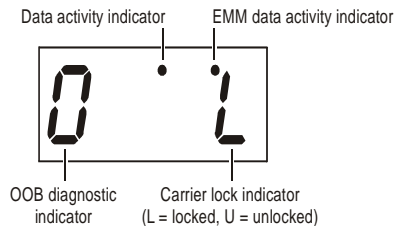

The Out-Of-Band Status fields are:

Field	Description									
OOB Frequency	Indicates the OOB tuner center frequency, from 70 to 130 MHz.									
Carrier Lock	Indicates whether the OOB receiver is locked to the carrier: <table border="1"> <thead> <tr> <th>OSD</th> <th>LED</th> <th>Description</th> </tr> </thead> <tbody> <tr> <td>YES</td> <td>L</td> <td>Carrier locked</td> </tr> <tr> <td>NO</td> <td>U</td> <td>Carrier unlocked</td> </tr> </tbody> </table>	OSD	LED	Description	YES	L	Carrier locked	NO	U	Carrier unlocked
OSD	LED	Description								
YES	L	Carrier locked								
NO	U	Carrier unlocked								
Data	Indicates whether data is being carried by the OOB and EMM traffic, which is tracked separately: <table border="1"> <thead> <tr> <th>OSD</th> <th>LED</th> <th>Description</th> </tr> </thead> <tbody> <tr> <td>YES</td> <td>On</td> <td>OOB data detected within last 5 seconds</td> </tr> <tr> <td>NO</td> <td>Off</td> <td>OOB data not detected within last 5 seconds</td> </tr> </tbody> </table>	OSD	LED	Description	YES	On	OOB data detected within last 5 seconds	NO	Off	OOB data not detected within last 5 seconds
OSD	LED	Description								
YES	On	OOB data detected within last 5 seconds								
NO	Off	OOB data not detected within last 5 seconds								
EMM Data	Indicates whether EMM data is being carried on the OOB stream: <table border="1"> <thead> <tr> <th>OSD</th> <th>LED</th> <th>Description</th> </tr> </thead> <tbody> <tr> <td>YES</td> <td>On</td> <td>EMM data detected within last 5 seconds</td> </tr> <tr> <td>NO</td> <td>Off</td> <td>EMM data not detected within last 5 seconds</td> </tr> </tbody> </table>	OSD	LED	Description	YES	On	EMM data detected within last 5 seconds	NO	Off	EMM data not detected within last 5 seconds
OSD	LED	Description								
YES	On	EMM data detected within last 5 seconds								
NO	Off	EMM data not detected within last 5 seconds								

Field	Description
SNR	When carrier lock has been established, displays an estimate of the carrier signal-to-noise ratio in dB, with an explanation: <ul style="list-style-type: none"> ▪ GOOD — Good value ▪ FAIR — Marginal signal level, check the signal ▪ POOR — Unusable signal ▪ INVALID — Invalid SNR value
AGC	When carrier lock has been established, displays an estimate of the AGC as a percentage, with an explanation: <ul style="list-style-type: none"> ▪ GOOD — Good value ▪ FAIR — Marginal signal level, check the signal ▪ POOR — Unusable signal ▪ INVALID — Invalid AGC value
EMM Provider ID	Displays the conditional access stream for the set-top, in hexadecimal format.
EMM PID	Displays the packet identifier (PID) stream the set-top tunes to for EMM data, in hexadecimal format.
Network PID	Displays the network PID to which the set-top is tuned to receive network messages, in hexadecimal format.

d04 In-Band Status

This diagnostic displays the in-band status for the last attempted tuned channel. The information is updated every 5 seconds.

IN-BAND DIAGNOSTIC			
MODE:			64 QAM
CARRIER LOCK:			YES
DATA:			YES
SNR	32.0 dB		GOOD
AGC:	23	%	FAIR
5 SECOND ERROR COUNTS:			
UNCORRECTABLE:			1234
CORRECTABLE:			5678

Figure 4-5
LED display for in-band diagnostic

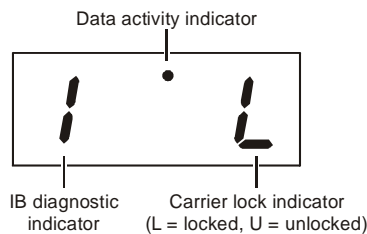

The In-Band Status fields are:

Field	Description									
Mode	The values displayed on the OSD are: <ul style="list-style-type: none"> ▪ ANALOG — analog channel ▪ 64 QAM — 64 QAM digital channel ▪ 256 QAM — 256 QAM digital channel 									
Carrier Lock	Indicates whether the in-band receiver is locked to the carrier. If a digital carrier is not present, it indicates the carrier is not locked: <table border="1" style="margin-left: 20px;"> <thead> <tr> <th>OSD</th> <th>LED</th> <th>Description</th> </tr> </thead> <tbody> <tr> <td>YES</td> <td>L</td> <td>Carrier locked</td> </tr> <tr> <td>NO</td> <td>U</td> <td>Carrier not locked</td> </tr> </tbody> </table>	OSD	LED	Description	YES	L	Carrier locked	NO	U	Carrier not locked
OSD	LED	Description								
YES	L	Carrier locked								
NO	U	Carrier not locked								
Data	Indicates whether data is being carried on the in-band stream. The indicators cover all packet processors regardless of the stream they are monitoring: <table border="1" style="margin-left: 20px;"> <thead> <tr> <th>OSD</th> <th>LED</th> <th>Description</th> </tr> </thead> <tbody> <tr> <td>YES</td> <td>On</td> <td>In-band data detected within last 5 seconds</td> </tr> <tr> <td>NO</td> <td>Off</td> <td>In-band data not detected within last 5 seconds</td> </tr> </tbody> </table>	OSD	LED	Description	YES	On	In-band data detected within last 5 seconds	NO	Off	In-band data not detected within last 5 seconds
OSD	LED	Description								
YES	On	In-band data detected within last 5 seconds								
NO	Off	In-band data not detected within last 5 seconds								
SNR	When carrier lock has been established, displays an estimate of the carrier signal-to-noise ratio in dB, with an explanation: <ul style="list-style-type: none"> ▪ GOOD — Good value ▪ FAIR — Marginal signal level, check the signal ▪ POOR — Unusable signal ▪ INVALID — Invalid SNR value 									
AGC	When carrier lock has been established, displays an estimate of the automatic gain control as a percentage, with an explanation: <ul style="list-style-type: none"> ▪ GOOD — Good value ▪ FAIR — Marginal signal level, check the signal ▪ POOR — Unusable signal ▪ INVALID — Invalid AGC value 									
5 Second Error Counts	Indicates the number of correctable and uncorrectable digital multiplex errors, up to 9999. It is updated every 5 seconds and reset each time the set-top is power cycled or another digital multiplex is tuned. The maximum value displayed is 9999, even if there were more than 9999 errors.									

d05 Unit Address

This diagnostic displays the set-top unit address:

```

UNIT ADDRESS

TVPC INSTALLED      NO
UNIT ADDRESS:
    123-45678-90123-456
OOB ADDRESSES:
NETWORK: 123-45678-90123-456
MULTICAST 16 ADDRESS FOR:      nnnn
    0x0000      0x0000
    0x0000      0x0000

MAC ADDRESSES:
DOCSIS:   xx xx xx xx xx xx
Ethernet: xx xx xx xx xx xx
1394:     xx xx xx xx xx xx
USB:      xx xx xx xx xx xx
Settop:   xx xx xx xx xx xx
  
```

Figure 4-6
LED display of a unit address

The LED display shows the unit address in five segments:

- Segment 1: 123-
- Segment 2: 4567
- Segment 3: 8-90
- Segment 4: 123
- Segment 5: -456

The Unit Address fields are:

Field	Description
TvPC Installed	Indicates whether the TVPC renewable security system is installed: <ul style="list-style-type: none"> ▪ YES — TvPC is installed ▪ NO — TvPC is not installed
Unit Address	A unique decimal number that indicates the set-top unit address or physical address.
OOB Addresses	
Network	The set-top network address displayed in decimal format.
Multicast 16 Address For	Specifies the stream to which the OOB multicast 16 addresses are assigned. The stream type and multicast 16 addresses cycle on the OSD every 5 seconds. The valid stream types <i>nnnn</i> are: <ul style="list-style-type: none"> ▪ Net — Network ▪ EMM — EMM ▪ SCC — SCC_ECM ▪ Dnld — Download ▪ Data — Data ▪ Poll — Polling packet identifier (PID) <p>The 16-bit multicast address is displayed in 4-byte hexadecimal format. The Multicast 16 addressed messages filter on a 16-bit multicast address. The user processor can define up to four multicast addresses in hardware and any message matching one of the four is processed. Messages not matching the multicast address are discarded.</p>
MAC Addresses	The DOCSIS, Ethernet, 1394, USB, and set-top MAC addresses are stored in protected flash and displayed in hexadecimal format.

d06 Current Channel Status

This diagnostic displays a status of the last attempted tuned channel on the in-band stream. The channel type determines the status display.

This is an example analog channel OSD:

CURRENT CHANNEL STATUS		
TYPE:	ANALOG	<i>aaa</i>
PICTURE CARRIER	077.2500 MHz	
AUTHORIZED:	YES	
PURCHASABLE:	YES	
PURCHASED:	YES	
PREVIEW:	YES	

This is an example digital channel OSD:

CURRENT CHANNEL STATUS		
TYPE:	DIGITAL	<i>aaa 0xbb</i>
INBAND FREQUENCY:	199.2500 MHz	
AUTHORIZED:	YES	
PURCHASABLE:	YES	
PURCHASED:	YES	
PREVIEW:	YES	
MPEG VIDEO LOCK	YES	
MPEG AUDIO LOCK	YES	
PCR LOCK	YES	

Figure 4-7
Current channel status LED displays

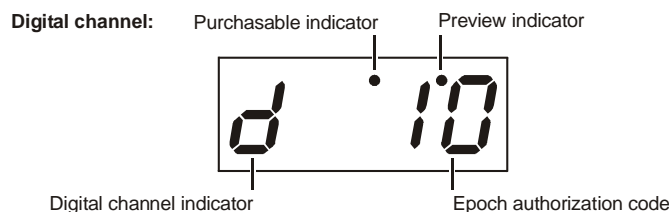
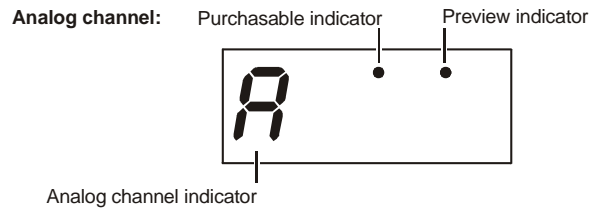

The Current Channel status fields are:

Field	Description									
Type	Indicates whether the channel is analog or digital:									
	<table border="0"> <thead> <tr> <th>OSD</th> <th>LED</th> <th>Description</th> </tr> </thead> <tbody> <tr> <td>ANALOG</td> <td>A</td> <td>Analog</td> </tr> <tr> <td>DIGITAL</td> <td>d</td> <td>Digital</td> </tr> </tbody> </table>	OSD	LED	Description	ANALOG	A	Analog	DIGITAL	d	Digital
OSD	LED	Description								
ANALOG	A	Analog								
DIGITAL	d	Digital								
aaa	<p>Displays the encryption mode for the channel on the OSD and LED. It is updated every 5 seconds.</p> <p>For an analog channel:</p> <ul style="list-style-type: none"> ▪ SCR – scrambled ▪ CLR – clear <p>For a digital channel:</p> <ul style="list-style-type: none"> ▪ ENC – encrypted ▪ UNE – unencrypted ▪ CLR – clear 									
bb	(Digital channels <i>only</i>) The current epoch authorization reason is displayed in the hexadecimal format <i>0xbb</i> on the OSD and LED.									
Picture Carrier	(Analog channels <i>only</i>) The analog frequency is displayed as the picture carrier.									
In-Band Frequency	(Digital channels <i>only</i>) The center RF carrier frequency for the digital service. It can be from 54 to 860 MHz.									
Authorized	Indicates whether the set-top is authorized for the currently tuned service:									
	<ul style="list-style-type: none"> ▪ YES — authorized ▪ NO — not authorized 									
Purchasable	Indicates whether the current program can be purchased for viewing:									
	<table border="0"> <thead> <tr> <th>OSD</th> <th>LED</th> <th>Description</th> </tr> </thead> <tbody> <tr> <td>YES</td> <td>on</td> <td>Can be purchased</td> </tr> <tr> <td>NO</td> <td>off</td> <td>Cannot be purchased</td> </tr> </tbody> </table>	OSD	LED	Description	YES	on	Can be purchased	NO	off	Cannot be purchased
OSD	LED	Description								
YES	on	Can be purchased								
NO	off	Cannot be purchased								
Preview	Indicates whether the current program is in preview mode:									
	<table border="0"> <thead> <tr> <th>OSD</th> <th>LED</th> <th>Description</th> </tr> </thead> <tbody> <tr> <td>YES</td> <td>on</td> <td>In preview mode</td> </tr> <tr> <td>NO</td> <td>off</td> <td>Not in preview mode</td> </tr> </tbody> </table>	OSD	LED	Description	YES	on	In preview mode	NO	off	Not in preview mode
OSD	LED	Description								
YES	on	In preview mode								
NO	off	Not in preview mode								
MPEG Video Lock	Indicates whether the video processor is locked to the video stream:									
	<ul style="list-style-type: none"> ▪ YES — locked ▪ NO — not locked 									
MPEG Audio Lock	Indicates whether the audio processor is locked to the audio stream:									
	<ul style="list-style-type: none"> ▪ YES — locked ▪ NO — not locked 									
PCR Lock	Indicates whether the in-band receiver is locked to the program clock reference (PCR):									
	<ul style="list-style-type: none"> ▪ YES — locked ▪ NO — not locked 									

d07 RF Modem (Upstream)

This diagnostic displays the RF modem status, if an RF modem is installed in the set-top. The information is updated each time this diagnostic is displayed.

RF MODEM	
STATUS:	CONFIGURED
CENTER FREQUENCY:	9.0000 MHz
REQUESTED POWER LEVEL:	23 dB
ACTUAL POWER LEVEL:	20 dB
REPORT BACK ADDRESS:	xx xx xx xx
LAST RB ATTEMPT TIME:	xxxxxxxxxx

Figure 4-8
RF upstream modem LED display

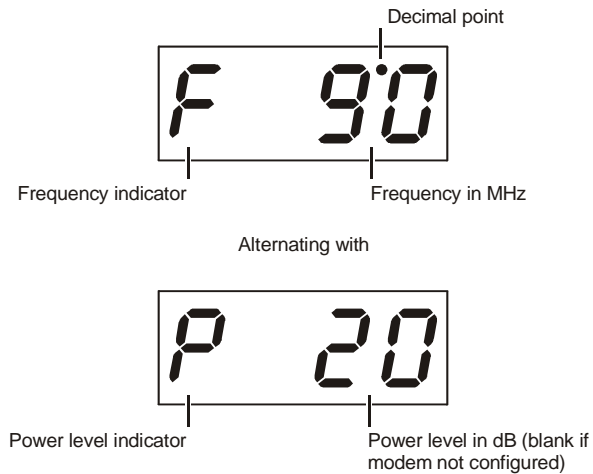

The RF Modem fields are:

Field	Description
Status	CONFIGURED or NOT CONFIGURED.
Center Frequency	The RF modem center frequency is displayed on the OSD and LED in MHz.
Requested Power Level	The value assigned to the set-top during RF leveling, in dB or blank if not configured.
Actual Power Level	The power level is displayed on the OSD and LED in dB or is blank if the power level has not been set.
Report Back Address	Displayed in 4-byte hexadecimal format, if configured.
Last RB Attempt Time	The last attempted report back by the set-top, in GPS seconds.

d08 Code Modules

This diagnostic includes information about the firmware loaded in flash memory and all non-volatile code versions are installed on the set-top. When the native suite is running, the diagnostics of the application operating system and all associated objects should be accessible.

CODE MODULES			
BOOTLOADER:	04.00		
FIRMWARE:	08.01		
DIGITAL SECURE PROCESSOR:		01	
ANALOG SECURE PROCESSOR:		8404	
OBJECT / VER		STATUS	SEGS/TIME
tcf_0801	08.01	ENABLED	xxxxxxxxxx

Figure 4-9
LED display for code modules

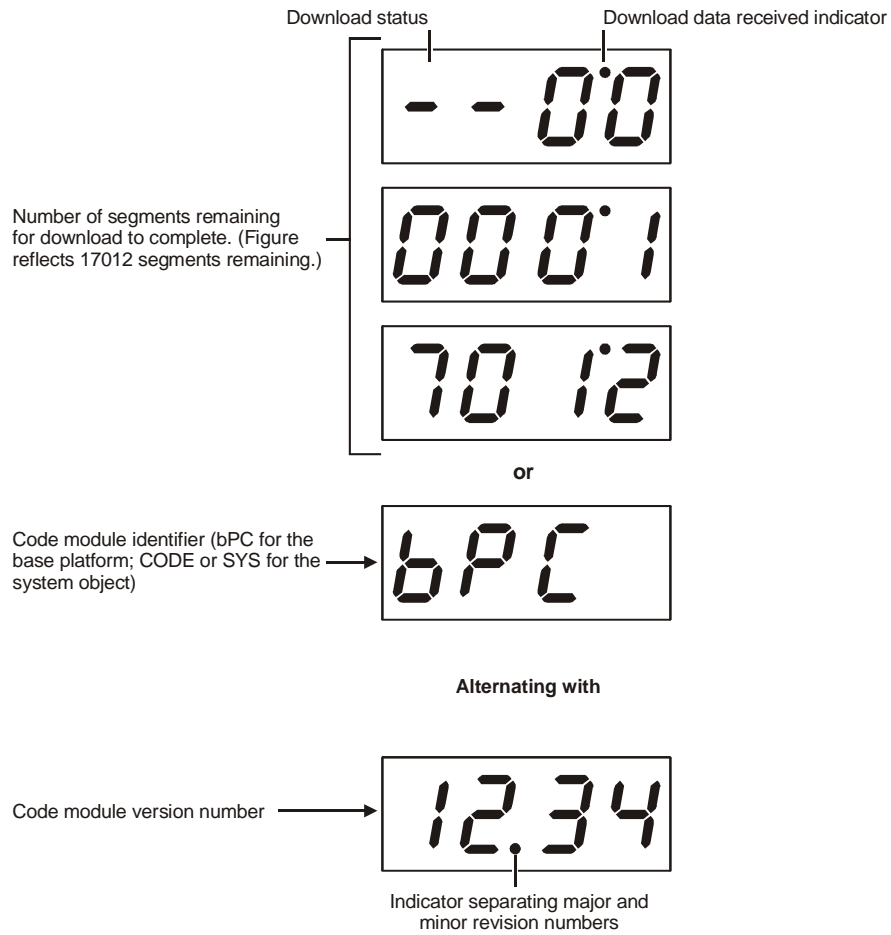

The Code Modules fields are:

Field	Description		
Bootloader	Indicates the boot loader version and major and minor revision numbers in ASCII format.		
Firmware	Indicates the firmware version in ASCII format.		
Digital Secure Processor	Indicates the digital secure processor version in ASCII format.		
Analog Secure Processor	Indicates the analog secure processor version in ASCII format.		
Downloadable Object Information Table	The information displayed for each object depends on the running environment.		
Object / Ver	Indicates the name and versions of all objects loaded, or being loaded, onto the set-top, in ASCII format. If a download is not in progress, the LED displays the current environment running and version number as shown in Figure 4-9. On the LED, "bPC" represents base platform or Thin Client code.		
Status	Indicates the object status displayed on the OSD and LED. It is updated every 5 seconds while you display the diagnostic.		
	OSD	Status	Description
	MEM ALLOC	Allocated	Memory for object is allocated
	LOADING	Loading	Object is being loaded
	STARTING	Enabling	Object is being started (the constructor is running)
	ENABLED	Enabled	Object is running
	ENA-NOT RUN	Enabled_Not_Runnable	Object is enabled, but cannot run
	STOPPING	Disabling	Object is being stopped (the destructor is running)
	DISABLED	Disabled	Object has been disabled
	DIS-NOT RUN	Disabled_Not_Runnable	Object is disabled and cannot run
	DELETING	Deleting	Object is being deleted
	POSTPONED	Postponed	Object cannot run on the current system; it will be enabled during the next boot
	CONNECTED	Connect	Connected to download PID – awaiting data
	PEND CONNECT	TryingToConnect	Trying to connect
Segs/Time	Indicates the segments remaining in the download or the total time of the completed download in GPS seconds, displayed on the OSD and LED.		

d09 Memory Configuration

This diagnostic displays the set-top memory configuration. The information is updated when you display the diagnostic.

MEMORY CONFIGURATION		
SYSTEM RAM:	32	MB
FLASH:	16	MB
NVRAM:	256	KB

There is no LED display for this diagnostic.

The Memory Configuration fields are:

Field	Description
System RAM	The allocated system RAM in MB.
Flash	The allocated flash memory in MB.
NVRAM	The allocated NVRAM in KB.

d10 Keypad - LED

This diagnostic verifies the functionality of the LEDs and the front-panel keypad. Each highlighted character corresponds with a front-panel key press.

<	>	U	D	Î	M	P	B	G	S	+	-
---	---	---	---	---	---	---	---	---	---	---	---

d11 Interface Status

The Interface Status diagnostic displays when running in base platform or Thin Client. There is no LED display. The information on the OSD is updated when you display the diagnostic.

INTERFACE STATUS	
DOCSIS TUNER & XMITTER:	INST
1394 I/O DEVICE:	NOT INST
ACTIVE PORTS	0
DATA XMISSION	NO
5C IMPLEMENTATION	0
LOOP STATUS	NO
ROOT STATUS	YES
CYCLE MASTER STATUS	YES
USB I/O DEVICE:	INST
10BT ETHERNET DEVICE:	INST
PARALLEL PORT:	INST
IR BLASTER:	INST
HARD DRIVE STATUS:	INST
SMART CARD:	INST

DVI PORT	
DEVICE CONNECTED:	YES/NO
REPEATER:	YES/NO
VIDEO XMISSION:	ACTIVE/NOT ACTIVE
HDCP ENABLED:	YES/NO
VIDEO CONSTRAINED	YES/NO
OUTPUT FORMAT	XXXX x XXXX
ASPECT RATIO:	xx:x
EDID DATA	

The Interface Status fields are:

Field	Description
DOCSIS Tuner & Xmitter	INST (installed) or NOT INST (not installed)
1394 I/O Device	INST (installed) or NOT INST (not installed)
USB I/O Device	INST (installed) or NOT INST (not installed)
10BT Ethernet Device	INST (installed) or NOT INST (not installed)
Parallel Port	INST (installed) or NOT INST (not installed)
IR Blaster	INST (installed) or NOT INST (not installed)

Field	Description
Hard Drive Status	INST (installed) or NOT INST (not installed)
Smart Card	INST (installed) or NOT INST (not installed)
DVI Port	If a device is connected to the DVI port <i>only</i> , the following diagnostics display to help troubleshoot problems with the DVI interface. They all display "N/A" if no device is connected to the DVI port or the value is invalid or cannot be retrieved.
Device Connected	Indicates whether a device is connected to the set-top — Yes or No.
Repeater	Indicates whether the connected device is a repeater — Yes or No.
Video Xmission (transmission)	Indicates whether the set-top is transmitting video over the DVI port — Not Active or Active.
HDCP Enabled	Indicates whether the set-top is using HDCP to encrypt video transmitted over the DVI link — Yes or No. If the Video Xmission status is Not Active, the HDCP Enabled status is No.
Video Constrained	Indicates whether the set-top is constraining the video sent through DVI — Yes or No. If the Video Xmission status is Not Active, the Video Constrained status is No.
Output Format	Indicates the timing format of the video sent through DVI: <ul style="list-style-type: none"> ▪ 1920 x 1080I — 1920 pixels wide by 1080 pixels high, interlaced ▪ 1280 x 720P — 1280 pixels wide by 720 pixels high, progressive ▪ 720 x 480P — 720 pixels wide by 480 pixels high, progressive ▪ 720 x 480I — 720 pixels wide by 480 pixels high, interlaced ▪ 640 x 480P — 640 pixels wide by 480 pixels high, progressive
Aspect Ratio	Indicates the aspect ratio of the video sent through DVI — 3:4 or 16:9.
EDID Data	Indicates the video timing formats that were read from the Extended Display Identification Data (EDID) registers for the connected device, in particular the detailed timing description blocks. The list displays all of the formats that the set-top could read up to a maximum of 12 formats. If the set-top cannot read any formats, EDID Data is blank. An asterisk (*) after the aspect ratio means the set-top supports the format. If more than twelve video timing formats are discovered, the supported formats <i>only</i> are listed first followed by any remaining formats, up to twelve.

d12 User Setting Status

This diagnostic displays the user settings. The format may vary. The information on the OSD and LED is updated when you display the diagnostic.

USER SETTING STATUS	
TV TYPE	16:9
YPbPr OUTPUT	1080i
4:3 OVERRIDE	480i
CLOSED CAPTION	ENABLED
PEN SIZE	STANDARD
FONT STYLE	MONO SERIF
FOREGROUND COLOR	BLACK
FOREGROUND OPACITY	AUTO
BACKGROUND COLOR	WHITE
BACKGROUND OPACITY	AUTO
SERVICE SELECTION	PRIMARY LANGUAGE
SETTINGS	USER
RESTORE DEFAULTS	

The User Setting Status fields are:

Field	Description
TV Type	<p>The aspect ratio. Defaults to 16:9. Options are 16:9 for wide screen TVs or for standard TVs:</p> <ul style="list-style-type: none"> ▪ 4:3 LETTERBOX fits high-definition programming on the screen by placing black bars at the top and bottom ▪ 4:3 PAN/SCAN fills the screen by cropping the left and right edges of high-definition programming
DVI/YPbPr Output	<p>The video display format for the component video outputs. Defaults to 1080i. Options are 1080i, 720p, 480p, or 480i. Some TVs only support certain display formats. Check the TV user manual for more information.</p> <p>If you are not using an HDTV, selecting a format other than 480i causes the on-screen display to go blank. If this occurs, view the settings on the LED panel to change the format back to 480i.</p> <p>If you are not using the DVI video connection, the DVI/YPbPr OUTPUT setting displays as YPbPr OUTPUT.</p>

Field	Description
4:3 Override	<p>The display format used for 4:3 standard-definition programming. If the YPrPb Output is set to 1080i, 720p, or 480p, this setting defaults to 480i. If the YPrPb Output is set to 480i, this setting defaults to OFF and cannot be changed. Options are:</p> <ul style="list-style-type: none"> ▪ OFF displays non-high-definition programs having a 4:3 aspect ratio in wide screen format. On an HDTV, black bars display on the left and right of the picture. Selecting OFF for a 4:3 TV may result in a small picture with black bars around it. ▪ 480i displays non-high-definition programs in their original 480i format. Some TVs cannot display 480i format on their component video inputs (YPbPr). Check the TV user manual for more information. Graphics overlaying the video are displayed. ▪ 480p converts non-high-definition TV programs to a higher-quality 480p format. Some TVs cannot display 480p format on their component video inputs (YPbPr). Check the TV user manual for more information. <i>Graphics overlaying the video are not displayed when 4:3 OVERRIDE is set to 480p.</i>
Closed Caption	Displays whether closed captions are ENABLED or DISABLED.
Pen Size	Displays the selected pen size — Auto (controlled by the closed caption stream), Standard, Large, or Small.
Font Style	<p>Displays the selected font style:</p> <ul style="list-style-type: none"> ▪ AUTO — The font style is controlled by the closed caption stream. ▪ MONO SERIF — Monospaced with serifs ▪ PROPORTION SERIF — Proportionally spaced with serifs ▪ MONO NO SERIF — Monospaced without serifs ▪ PROPORTION NO SERIF — Proportionally spaced without serifs ▪ CASUAL — Casual font type ▪ CURSIVE — Cursive font type ▪ SMALL — Small capitals
Foreground Color	Displays the selected foreground color — Auto (controlled by the closed caption stream), White, Black, Red, Green, Blue, Yellow, Magenta, or Cyan.
Foreground Opacity	Displays the selected foreground opacity — Auto (controlled by the closed caption stream), Transparent, Translucent, Solid, or Flashing.
Background Color	Displays the selected background color — Auto (controlled by the closed caption stream), White, Black, Red, Green, Blue, Yellow, Magenta, or Cyan.
Background Opacity	Displays the selected background opacity — Auto (controlled by the closed caption stream), Transparent, Translucent, Solid, or Flashing.
Service Selection	<p>Displays the selected service selection:</p> <ul style="list-style-type: none"> ▪ AUTO — Service selection is controlled by the closed caption stream. ▪ PRIMARY LANGUAGE — Primary language set by the provider. ▪ SECONDARY LANGUAGE — Secondary language set by the provider. ▪ 3, 4, 5, or 6 — Set by the provider.
Settings	<p>Displays the selected setting:</p> <ul style="list-style-type: none"> ▪ AUTO — Closed caption settings are determined by the closed caption stream regardless of user modification. ▪ USER — The configured closed caption user settings are used.
Restore Defaults	Resets the user settings to their defaults.

d13 DVR/Hard Drive Status

This two-page diagnostic indicates the set-top DVR and hard-drive status.

DVR/Hard Drive Status Page:

DVR/Hard Drive Status		
DVR Status		
Enabled:	True	
Stream Indexer Ver:	131	
Content Record Ver:	2	
Encoder		
Number	Type	Quality
1	MPEG2	HIGH2
2	MPEG2	HIGH2
Drive	Record Capacity Remaining	
IDE0	xxxxxxxxxxxxxxxxxxxxxx	
vvv Scroll Down vvv		

The DVR/Hard Drive Status page fields are:

Field	Description									
Enabled	Indicates whether the DVR is enabled, based on the set-top configuration (connect/disconnect state) and resource availability (resource authorized; hard disk installed and functional): <table border="1"> <thead> <tr> <th>OSD</th> <th>LED</th> <th>Description</th> </tr> </thead> <tbody> <tr> <td>True</td> <td>En</td> <td>DVR enabled</td> </tr> <tr> <td>False</td> <td>Un</td> <td>DVR disabled</td> </tr> </tbody> </table>	OSD	LED	Description	True	En	DVR enabled	False	Un	DVR disabled
OSD	LED	Description								
True	En	DVR enabled								
False	Un	DVR disabled								
Stream Indexer Ver.	Indicates the stream indexer version number, displayed without leading zeros. For example, version 0000000065 is displayed as "65."									
Content Record Ver.	Indicates the content record version number, displayed without leading zeros.									
Encoder	Information about the analog encoder for the IEEE 1394 output and recording analog programs.									
Number	Indicates the encoder number — 1 or 2.									
Type	Indicates the encoder type — Not Inst(alled), MPEG2, Other, or Unknown.									
Quality	Indicates the encoder quality setting (video bit rate) for analog services <i>only</i> , which may change at any time through software: <ul style="list-style-type: none"> ▪ LOW1 — 1 Mbps ▪ LOW2 — 2 Mbps ▪ MEDIUM1 — 3 Mbps ▪ MEDIUM2 — 4 Mbps ▪ HIGH1 — 5 Mbps ▪ HIGH2 — 6 Mbps ▪ NOT AVAILABLE — the encoder is not enabled or configured 									

Field	Description
Drive	Indicates the drive type — IDE (internal), 1394, USB (external), or NOT AVAILABLE (neither enabled nor configured).
Record Capacity Remaining	Indicates the remaining recording capacity, in bytes.

Hard Drive Status Page:

Hard Drive Status			
Number of Installed Drives: 1			
Drive: 1	INTERNAL		
Model Number:	ST3120025ACE		
Device ID:	N/A		
Type:	IDE		
Total Size:	120 GB	Used	Allocated
System		1	238 MB
GPFS		2	2861 MB
PVR Content		10864	109944 MB
PVR Index		35	1431 MB
State	Active		
Temp (F)	118	Max Temp:	122
Over Temp	No	Count:	0

The Hard Drive Status page fields are:

Field	Description
Number of Installed Drives	The number of internal and external hard drives, up to a maximum of 9
Drive	The identification number sequentially assigned to each installed drive and whether the drive is INTERNAL or EXTERNAL
Model Number	The model number for the drive assigned at the factory
Device ID	A text string of up to 20 characters that identifies the disk drive. "N/A" is displayed if the value is invalid or cannot be retrieved.
Type	Indicates the drive type — IDE, 1394, USB, or Unkn(own)
Total Size	Displays the drive size in GB.
System, GPFS, PVR Content, and PVR Index	Displays the space used and allocated for each of the internal hard drive's 4 partitions — System, GPFS, PVR Content, and PVR Index — in MB for each partition. "N/A" displays if the value is invalid or cannot be retrieved.
State	Can be: <ul style="list-style-type: none"> ▪ Standby — The hard drive is working normally, but is at rest (the State returns to Active any time disc access is necessary). ▪ Active — The hard drive is accessing data. ▪ Failed — The hard drive hardware has failed.
Temp (F)	For an internal hard drive <i>only</i> , its temperature in degrees F.

Field	Description
Max Temp	For an internal hard drive <i>only</i> , its maximum temperature in degrees F.
Over Temp	<ul style="list-style-type: none"> ▪ Yes — The internal drive temperature exceeds 60° C. The LED Over-Temp Indicator is on and remains lit until the next over-temp sample is taken (at least once an hour). ▪ No — There is no over temp problem.
Count	The cumulative number of times that the hard drive temperature exceeds 60° C, with the temperature checked at least once an hour.

d14 Interactive Info

This diagnostic describes the interactive information that is displayed only when Thin Client platform is running. The information on the OSD and LED is updated at least once every 5 seconds while the diagnostic is displayed. This is an example of a code module display with status descriptions:

INTERACTIVE INFO	
IP ADDRESS:	0.0.0.0
UPM:	00000021
UPSTREAM ID:	0000
DOWNSTREAM ID:	0000
STATE:	UNCONFIG
MAC ABORT CNTR:	0000
SOCKET PORT STATE:	
0	UNUSED
1	UNUSED
2	UNUSED
3	UNUSED
4	UNUSED

Figure 4-10
Interactive Info LED display



The Interactive Info fields are:

Field	Description
IP Address	The IP address in dotted-decimal format <i>xxx.xxx.xxx.xxx</i> assigned by the NC 1500 to the set-top. 0.0.0.0 is displayed if the IP address is not configured or unknown.
UPM	The upstream modem address value is the same as the terminal ID assigned by the DAC 6000. It is a unique, system-generated, eight-digit integer between 1 and 16777215. 00000000 is displayed when the UPM is not configured or unknown.
Upstream ID	A four-digit decimal value from 0000 to 9999 assigned by the DAC 6000 to the set-top. 0000 is displayed if the Upstream ID is not configured or unknown.

Field	Description																																				
Downstream ID	A four-digit decimal value from 0000 to 9999 assigned by the DAC 6000 to the set-top. 0000 is displayed if the Downstream ID is not configured or unknown.																																				
State	Indicates the interactive status of the set-top:																																				
<table border="0"> <thead> <tr> <th style="text-align: left;">LED</th> <th style="text-align: left;">OSD</th> <th style="text-align: left;">Description</th> </tr> </thead> <tbody> <tr> <td>U</td> <td>UNCONFIG</td> <td>The set-top is not configured for the interactive system and platform should run as pre-interactive.</td> </tr> <tr> <td>C</td> <td>MAC_CONNECT</td> <td>The set-top is waiting to establish connection to MAC PID Stream.</td> </tr> <tr> <td>I dc</td> <td>INIT_WAIT_DC_OR_C</td> <td>The set-top is running in the interactive initialization state and waiting for the default configuration or the contention channel list messages.</td> </tr> <tr> <td>I L</td> <td>WAIT_LM_ACK</td> <td>The set-top is running in the interactive initialization state and waiting for Link Management Response ACK for Local Address Message.</td> </tr> <tr> <td>I SO</td> <td>WAIT_SO_ACK</td> <td>The set-top is running in the interactive initialization state and waiting for a Sign On acknowledgement.</td> </tr> <tr> <td>I LA</td> <td>WAIT_LA_OR_SO</td> <td>The set-top is running in the interactive initialization state and waiting for Logical Address or Sign On with verification Frequency message.</td> </tr> <tr> <td>S I</td> <td>INIT_STOPPED</td> <td>The set-top is in the interactive initialization state and the TransMode has stopped.</td> </tr> <tr> <td>r dc</td> <td>RUN_WAIT_DC_OR_C</td> <td>The set-top is running in the interactive state and waiting for the default configuration or the contention channel list messages.</td> </tr> <tr> <td>r</td> <td>RUNNING</td> <td>Interactive state is running, sending idle messages, and waiting for any prepare for poll or MAC messages.</td> </tr> <tr> <td>S</td> <td>RUN_STOPPED</td> <td>The interactive run state has stopped and set-top is waiting for status or transmission control message.</td> </tr> <tr> <td>00</td> <td>INVALID</td> <td>Set-top interactive state is unknown or invalid.</td> </tr> </tbody> </table>	LED	OSD	Description	U	UNCONFIG	The set-top is not configured for the interactive system and platform should run as pre-interactive.	C	MAC_CONNECT	The set-top is waiting to establish connection to MAC PID Stream.	I dc	INIT_WAIT_DC_OR_C	The set-top is running in the interactive initialization state and waiting for the default configuration or the contention channel list messages.	I L	WAIT_LM_ACK	The set-top is running in the interactive initialization state and waiting for Link Management Response ACK for Local Address Message.	I SO	WAIT_SO_ACK	The set-top is running in the interactive initialization state and waiting for a Sign On acknowledgement.	I LA	WAIT_LA_OR_SO	The set-top is running in the interactive initialization state and waiting for Logical Address or Sign On with verification Frequency message.	S I	INIT_STOPPED	The set-top is in the interactive initialization state and the TransMode has stopped.	r dc	RUN_WAIT_DC_OR_C	The set-top is running in the interactive state and waiting for the default configuration or the contention channel list messages.	r	RUNNING	Interactive state is running, sending idle messages, and waiting for any prepare for poll or MAC messages.	S	RUN_STOPPED	The interactive run state has stopped and set-top is waiting for status or transmission control message.	00	INVALID	Set-top interactive state is unknown or invalid.	
LED	OSD	Description																																			
U	UNCONFIG	The set-top is not configured for the interactive system and platform should run as pre-interactive.																																			
C	MAC_CONNECT	The set-top is waiting to establish connection to MAC PID Stream.																																			
I dc	INIT_WAIT_DC_OR_C	The set-top is running in the interactive initialization state and waiting for the default configuration or the contention channel list messages.																																			
I L	WAIT_LM_ACK	The set-top is running in the interactive initialization state and waiting for Link Management Response ACK for Local Address Message.																																			
I SO	WAIT_SO_ACK	The set-top is running in the interactive initialization state and waiting for a Sign On acknowledgement.																																			
I LA	WAIT_LA_OR_SO	The set-top is running in the interactive initialization state and waiting for Logical Address or Sign On with verification Frequency message.																																			
S I	INIT_STOPPED	The set-top is in the interactive initialization state and the TransMode has stopped.																																			
r dc	RUN_WAIT_DC_OR_C	The set-top is running in the interactive state and waiting for the default configuration or the contention channel list messages.																																			
r	RUNNING	Interactive state is running, sending idle messages, and waiting for any prepare for poll or MAC messages.																																			
S	RUN_STOPPED	The interactive run state has stopped and set-top is waiting for status or transmission control message.																																			
00	INVALID	Set-top interactive state is unknown or invalid.																																			
MAC Abort Cntr	This counter increments every time the MAC layer reaches the cell abort count limit. It is reset by the successful upstream transmission of a cell, for example, when the set-top receives an ACK. If the counter reaches the MAC abort count limit, the set-top assumes the MAC layer is unavailable due to noise, congestion, or some other problem. The set-top stops transmitting data upstream, reports an error to the calling function, and attempts to re-enter the network using the initialization process. 0000 is displayed as default or if the MAC Abort CNTR is not configured or unknown.																																				
Socket Port State	Indicates the socket mode and activity: <ul style="list-style-type: none"> ▪ UNUSED — The socket is not being used. ▪ OPENED — The socket is open. ▪ READY — The socket is ready to send or receive. ▪ RECEIVING — The socket is receiving data from the application server. ▪ SENDING — The socket is sending data to the application server. ▪ UNKNOWN — The socket state is invalid or unknown. 																																				

Section 5

Troubleshooting

This section provides troubleshooting guidelines. If problems still occur after performing the diagnostics, call the TRC for assistance as described in Section 1, “Introduction.”

Problem	Possible Solutions
The set-top will not power on.	<p>The set-top may have received a software update and may not power on while the new software is being installed. Try again in a few minutes.</p> <p>Verify that the AC power cord is connected to the set-top and an AC outlet. Unplug the set-top from the AC outlet, plug it back in, and then press the POWER button.</p> <p>If the set-top is connected to a switched outlet on another unit, verify that that unit is powered on. Unplug the power cord from the set-top's AC outlet, plug it back in, and then press the POWER button.</p> <p>Press the POWER button on the set-top front panel instead of the remote control. The batteries in the remote control may be depleted.</p>
The remote control does not work.	<p>Verify that the remote control is in “Cable” mode.</p> <p>Verify that there are no obstructions between the remote control and the set-top. Aim the remote control directly at the set-top front panel, not the TV or VCR.</p> <p>The angle between the remote control and the set-top may be too large. Stand in front of the set-top and not too far to either side.</p> <p>Press and release operation keys one at a time, firmly and deliberately.</p> <p>Try changing channels using the buttons on the set-top front panel.</p> <p>Check the batteries in the remote control. Install new batteries if needed.</p>
There is no audio when viewing cable channels.	<p>Verify that the MUTE button on the set-top or the remote control has not been pressed. Press MUTE on the remote control to restore sound.</p> <p>If the set-top audio output is connected to the TV, verify that the Mute button on the TV has not been pressed.</p> <p>If the set-top audio output is connected to a home theater receiver, verify that the receiver is set to the appropriate input source and the MUTE button on the receiver has not been pressed.</p> <p>Verify that you have the correct cables for the audio ports.</p> <p>Verify that the audio cables are firmly connected between the set-top and the TV, VCR, or home theater receiver.</p>
There is no audio from the center and/or surround speakers of a home theater receiver connected to the set-top.	<p>Not all Dolby Digital programs feature full 5.1 surround sound. In some cases, the programs may only contain left and right stereo audio.</p> <p>Verify that the S/PDIF cable (coaxial or optical) is firmly connected to the set-top and the home theater receiver.</p> <p>Verify that the home theater receiver is set to a surround sound audio mode (Dolby Digital, Dolby Pro Logic[®], or Dolby Pro Logic II).</p> <p>Verify that the receiver is properly configured to work with all connected speakers.</p>

Problem	Possible Solutions
There is no video on the TV screen.	<p>Verify that the TV is powered on and set to the appropriate input source for the set-top.</p> <p>Verify that the set-top is powered on and tuned to an authorized cable channel.</p> <p>Verify that the coaxial cable is firmly connected to the set-top and the wall jack.</p> <p>Verify that all video cables between the set-top and the TV are firmly connected.</p> <p>The set-top DVI output may not yet be enabled. Use the component video (Y Pb Pr) output instead.</p> <p>If the set-top video output is connected to a home theater unit, verify that the home theater unit is powered on and set to the appropriate input source.</p> <p>Not all HDTVs can display every output format (1080i, 720p, 480p, or 480i) available on the DCT6400 Series. To select a different format:</p> <ol style="list-style-type: none"> 1 Ensure that your set-top is plugged into a power outlet and is turned off. 2 Press the MENU key on the front panel. Your settings are displayed on the front panel. 3 Press the ▲ and ▼ keys to display the DVI/YPbPr OUTPUT setting. 4 Press the ▶ key to cycle through the available output formats until a picture displays on the TV.
There are no graphics, closed captions, or program guides appearing on the TV screen.	<p>The set-top cannot generate graphics on all video outputs at all times. If the set-top is set to 1080i, 720p, or 480p output format, graphics are only available on the high definition video outputs (DVI and component video). If the set-top is set to 480i, graphics are available on all video outputs. For more information, see “Graphics Overlaying the Video” in Section 3, “Installation.”</p> <p>If the set-top is connected to a standard definition (SD) TV, verify that the set-top is configured to use the 480i output mode.</p> <p>Verify that closed captions on the set-top have been enabled in the User Settings menu.</p>
There are black bars to the right and left of the picture.	<p>Wide screen TVs display 4:3 programs in this format unless set to Stretch. Turn on the 4:3 OVERRIDE feature in the User Settings menu. This enables most wide screen TVs to stretch the video to fill the screen (see the TV manual for information about stretching 4:3 video).</p> <p>If the set-top is connected to a wide screen TV, verify that the TV TYPE is set to 16:9 in the User Settings menu.</p> <p>Many HD programs are broadcast in pillar-box format with black bars to the left and right of the picture. These programs are broadcast in 16:9 HD formats even though the video is not 16:9.</p>

Problem	Possible Solutions
There are black bars above and below the picture.	<p>All 4:3 HDTVs display HD programs in letterbox format (black bars above and below the picture) because of the shape of the display screen.</p> <p>Turn on the 4:3 OVERRIDE feature in the User Settings menu. This enables most standard screen TVs to display a full screen picture when the set-top is tuned to a 4:3 program.</p> <p>Set the TV TYPE to 4:3 Pan-Scan. This enables the set-top to remove the black bars above and below the picture when possible.</p> <p>Some SD programs are broadcast in the letterbox format with black bars above and below the picture. Some wide screens TVs offer a zoom feature that may be able to remove the black bars (see the TV manual for information about zooming 4:3 video).</p>
There are black bars on all four sides of the picture.	<p>This may occur on a 4:3 TV if the 4:3 OVERRIDE setting is OFF. To cause 4:3 SD programming to fill the screen, depending on the capabilities of the TV, set 4:3 OVERRIDE to 480i or 480p.</p> <p>This may occur on a 16:9 TV if the active video for an SD broadcast is in letterbox format. To confirm, wait for a commercial or look for a graphic, such as a network logo. If the commercial fills the screen from top to bottom, or the graphic appears below the active video, the program is being letterboxed by the broadcaster. You can minimize this by activating the zoom feature on the TV.</p> <p>A broadcaster may include black bars on either side of a wide screen broadcast. This is called a "hybrid" aspect ratio and results in a black border surrounding the video on a 4:3 TV. Because this is part of the broadcast, the set-top cannot correct the video. You may be able to minimize the border using the zoom feature on the TV.</p>
There is a humming noise.	<p>The DCT6400 series provides an internal fan to cool the integrated hard drive. During normal operation, the fan emits a low humming noise, similar to a personal computer. The volume varies occasionally when the fan speed adjusts to changes in the temperature around the set-top. The hard drive remains on even when the set-top is turned off.</p>

Appendix A

Specifications

Input frequency	
Video	54 to 860 MHz
DOCSIS	Up to 860 MHz
HRC/IRC frequency assignments	Downloadable
Number of channels	136 carriers per cable, 1 or 2 cables
Analog	1 channel per carrier
Digital	More than 1 channel per carrier, content dependent
Input analog video level	0 dBmV to +15 dBmV
Input digital average level	64 QAM: -18 dBmV to +5 dBmV 256 QAM: -12 dBmV to +5 dBmV
Data carrier	QPSK-modulated carrier
Frequency	Agile Receiver 70 – 130 MHz
Bandwidth	1.5 MHz
Level	-15 dBmV to +5 dBmV
Mechanical security	Standard: security screws, unichassis construction
Operating environment range	
Temperature	15° to 40°C (32° to 104°F)
Humidity	5% to 95% (noncondensing)
ac voltage	105 to 125, 60 Hz
Power dissipation	40 W nominal at 115 Vac
Size	17.13 in. × 12.75 in. × 2.75 in.
Weight	11.5 pounds
Hard Disk	DCT6408: 80 MB DCT6412: 120 MB DCT6416: 160 MB

Appendix B Connection Record

To ease reconnection if equipment is moved or added to the system, you can use a copy of this or a similar diagram to record the connections between components for the subscriber:

Figure B-1
Connection record

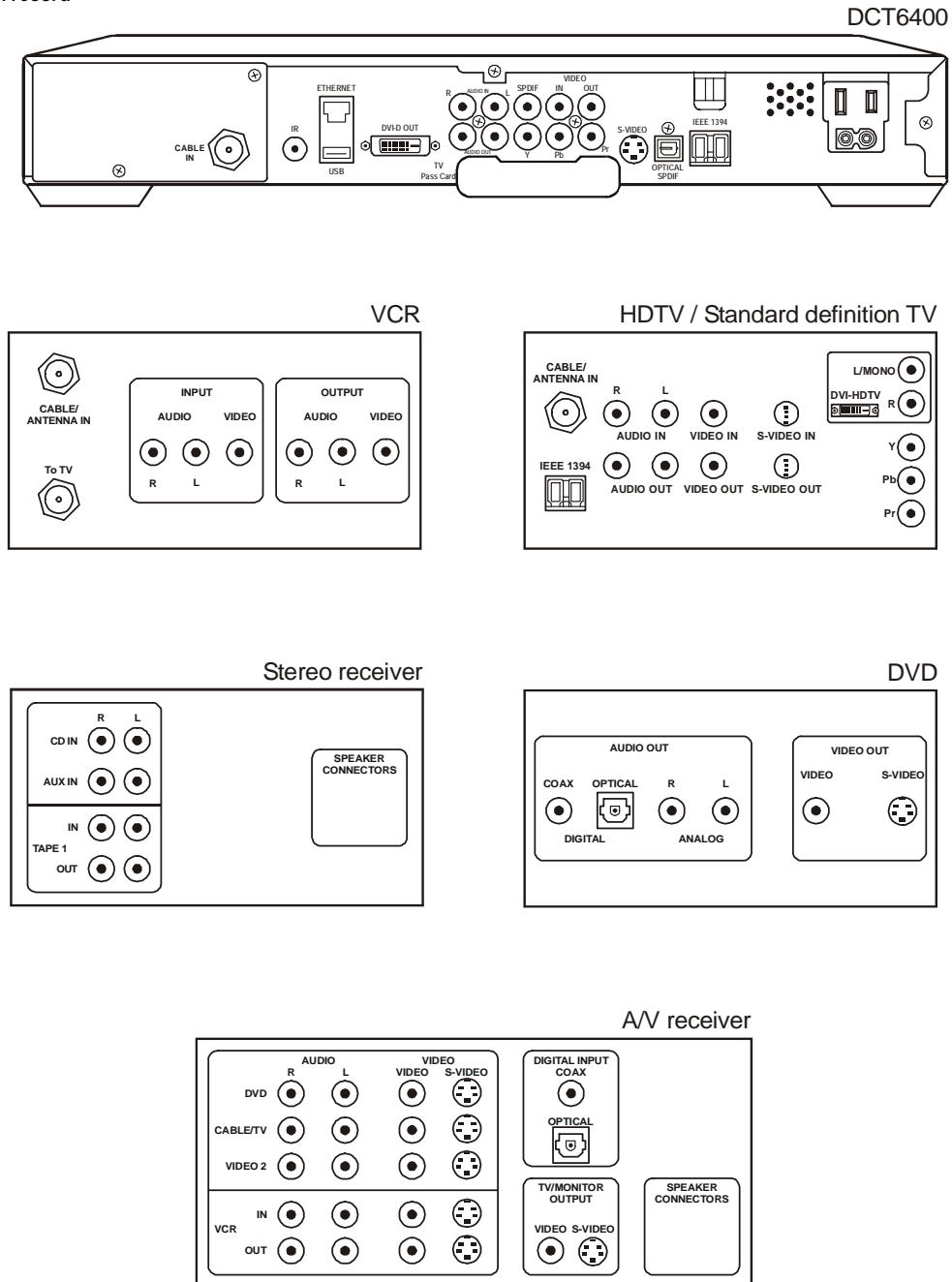

Before connecting or changing cable connections, disconnect the power from the set-top. Do not place another component or object on top of the set-top.

Abbreviations and Acronyms

AGC	automatic gain control
ASTB	Advanced Set-top Box
CRC	cyclic redundancy check
CSR	Customer Service Representative
DAC 6000	Digital Addressable Controller 6000
DOCSIS	Data Over Cable Service Interface Specification
DRAM	dynamic random access memory
DVI	Digital Video Interface
DVR	Digital Video Recorder
EDID	Extended Display Identification Data
EMM	entitlement management message(s)
FLASH	A type of nonvolatile memory
GPS	global positioning system
HDTV	high-definition television
HRC	harmonically related carriers
IPG	interactive program guide
IPPV	Impulse Pay-Per-View
IR Blaster	Infrared Blaster
IRC	incrementally related carriers
ITU	International Telecommunication Union
MPAA	Motion Picture Advisory Association
MPEG-2	Motion Picture Experts Group-2 compression standard for digital audio and video encoding
NVOD	near video on demand
NVRAM	non-volatile random-access memory
OSD	on-screen display
PCR	program clock reference
PID	packet identifier
PPV	Pay-Per-View
QAM	Quadrature Amplitude Modulation
QPSK	Quadrature Phase Shift Keying
RSA	Return for Service Authorization
SD	standard definition
SNR	signal-to-noise ratio
S/PDIF	Sony Philips Digital Interface Format
TCP/IP	Transmission Control Protocol/Internet Protocol
TRC	Technical Response Center

TvPC	TV PassCard
USB	Universal Serial Bus
VOD	video on demand
Y Pb Pr	component video connectors

Visit our website at:
www.motorola.com



512660-001
5/04

MGBI